



CLYMENE

KMC-CE&CH Series Vertical Machining Center Machinery

CONTENTS

I . KMC-CE series

- 04 CE Series Machine Main Features
- 05 High-Rigidity Structure and High-Positioning Accuracy of CE Series
- 07 Three-Axis Transmission System of CE Series
- 09 High-Strength Spindle Head of CE Series
- 10 Automatic Tool Changer System of CE Series
- 11 Floor space Diagram and Working Table Dimension Diagram of CE Series
- 14 Torque Diagram of CE Series

KMC-115CE

KMC-168CE

KMC-136CE



A thought forms a magnificent and vibrant world,
and it is an extremely beautiful and lush place.

II. KMC-CH series

- 16 CH Series Console Main Features
- 17 High-Rigidity Structure and High-Positioning Accuracy of CH Series
- 18 High-Strength Spindle Head of CH Series
- 18 High-Speed Module Processing of CH Series
- 19 Automatic Tool Changer System of CH Series
- 20 Floor space Diagram and Working Table Dimension Diagram of CH Series
- 22 Torque Diagram of CH Series

III. KMC-CE&CH

- 24 Machine Specification Table of CE&CH Series
- 25 Standard Accessories & Special Accessories of CE&CH Series

KMC-116CH



KMC-158CH

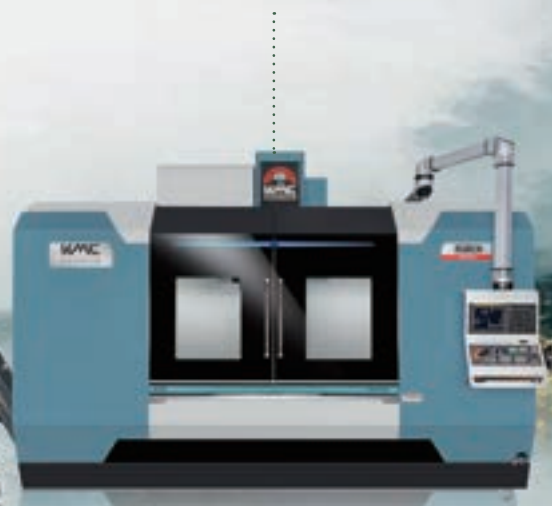

I

K M C - C E s e r i e s



KMC-CE series

Machine Main Features

1. The main castings are made of high-grade Meehanite cast iron, with strong rib strengthening design and rigidity characteristics. When processing at high speed, it highlights its extraordinary stability.
2. The exterior sheet metal has no external leakage, reinforcing ribs and wires, and the machine is designed in cubic shape.
3. Visualized surrounding light ribbon.
4. Lightweight CRT boom.
5. In-house made rate of parts reaches 74.5%.
6. Intelligent operation platform (IPROS MX) and intelligent temperature control system (spindle temperature auxiliary system) can be set to improve the operation process. It is an innovative vertical machining center machine with great economic benefits.



KMC-CE series

High-Rigidity Structure and High-Positioning Accuracy

KMC-115CE
(3745×3819×3119mm)



Stability

KMC-115CE

1. It has an original stable structure, and its performance in rigidity and stability of the machine structure is far superior to that of general models of the same level.

KMC-136CE

1. The lightweight design of this series structure shows the best capability of high-speed processing.
2. Two slide rail bases, fully supported in the effective stroke of three axes, almost has no hanging place, perfectly avoiding the phenomenon of overhanging and sagging.

Lightweight

KMC-136CE
(3500×4284×3042mm)

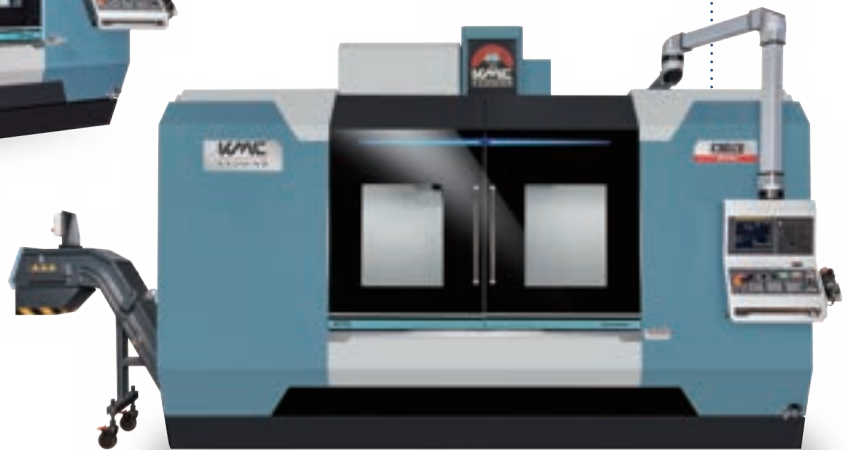

KMC-168CE

1. Different from the general hollow box and rib type design. We adopt an unique keel design with strong bending and torsion resistance.
2. The column hydrodynamics design, cross closed design and keel design can improve the bending rigidity by 42% and torsion rigidity by 17% compared with the general square closed design. Its stable structure lays a good foundation for the machine.
3. The center span of the base roller-type four-line rail is 1900mm (74.8"), and the full-stroke support design of the Y-axis saddle can eliminate the suspension of the X-axis working table and ensure the best support rigidity and dynamic accuracy.
4. Six telescoping cover (front three and back three) are used for Y axis to prevent the accumulation of chips and accelerate the removal of chips.

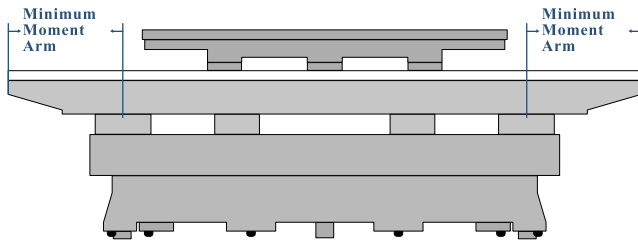

Kao Ming machine is designed with minimum moment arm and minimum overhang and sag.

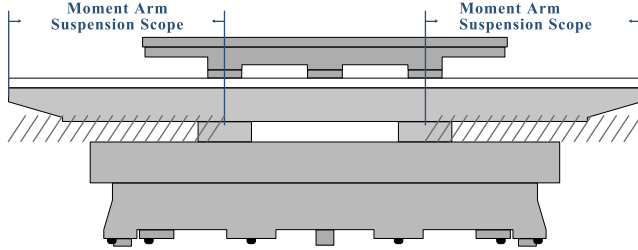

The moment arm is large, the overhang and sag are large.

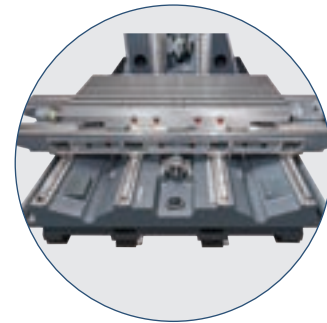

Four linear guide ways



Telescoping cover



Keel Structure

KMC-168CE
(4206×4314×3507mm)



Comparison diagram of rigidity between general structure and keel structure

		Relatives Anti-Bending Rigidity			Relatives Anti-Torque Rigidity			Relatives Material Volume		
		50	%	100	50	%	100	100	%	150
				m.kpl.			m.kpl.			m.kpl.
		100%			100%			100%		
				142%			117%			157%

KMC-CE series

Three-Axis Power Transmission System

KMC-115CE

1. Three axis servo motor and ballscrew drive directly, with good accuracy.
2. The two ends of a ballscrew with a diameter of $\varnothing 50\text{mm}$ are supported by heavy-duty bevel ball bearings; Pre-loaded bearing and pre-tensioned ball screw ensure the rigidity and accuracy of the system.
3. All three axes are equipped with roller-type linear guide way, and the long-span design between linear guide way can effectively improve the stability of load support.
4. The Three Axis sliders are configured as 4/4/4 sliders.

KMC-136CE

1. The Three-Axis transmission system adopts three step cooling design: motor board with cooling oil circuit, cooling system in bearing seat, inner cooled ballscrew. The purpose is to take away the heat generated by the transmission system in the most effective way to improve the mechanical accuracy.
2. The sharing rate of Three-Axis transmission mechanism reaches 96%.
3. The two ends of a ballscrew with a diameter of $\varnothing 50\text{mm}$ are supported by heavy-duty bevel ball bearings; Pre-loaded bearing and pre-tensioned ballscrew ensure the rigidity and accuracy of the system.
4. Three axes adopt precision (P) roller linear guide way
5. The Three-Axis sliders are configured as 6/4/6 sliders.

Precision (P) Roller-Type linear guide way

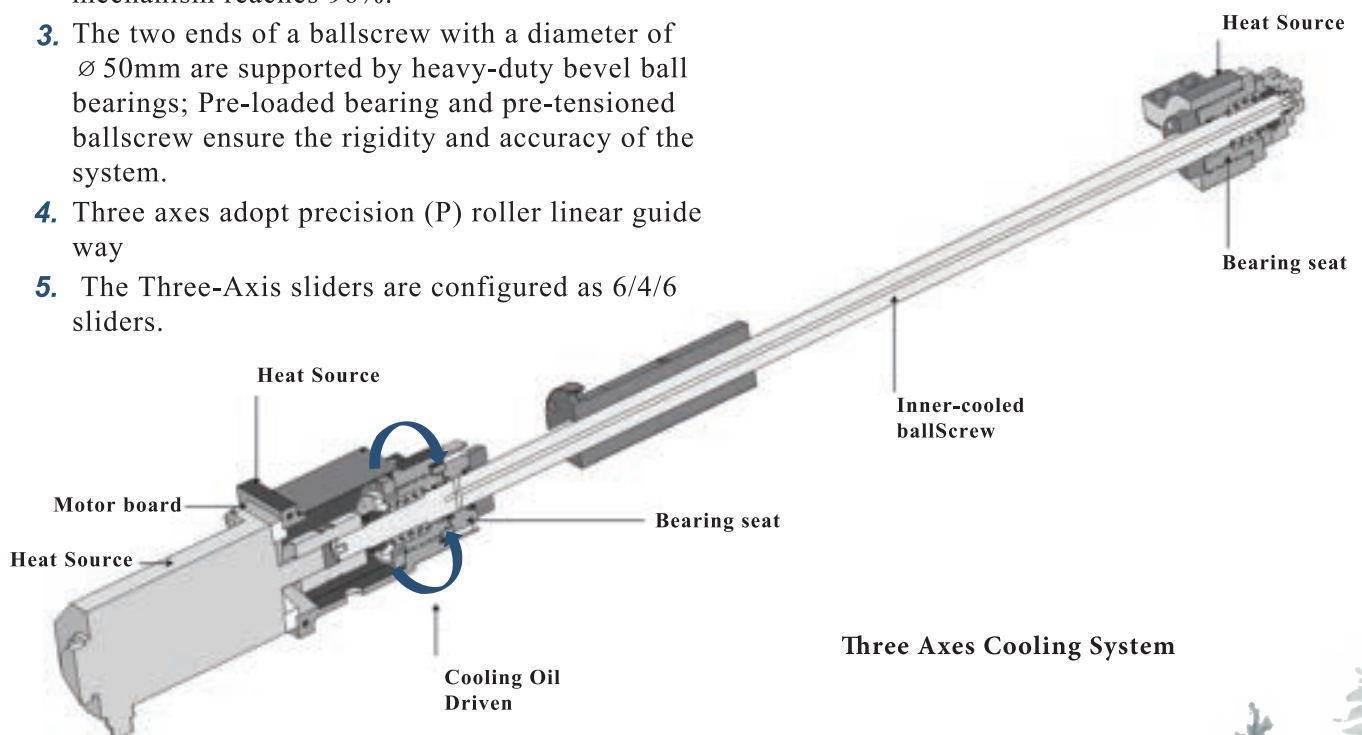
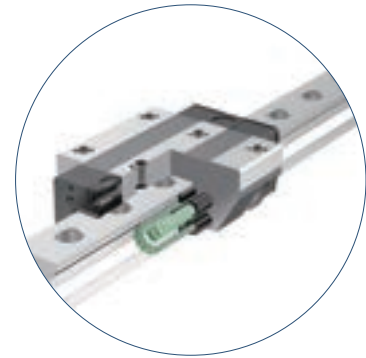

Three Axes Cooling System

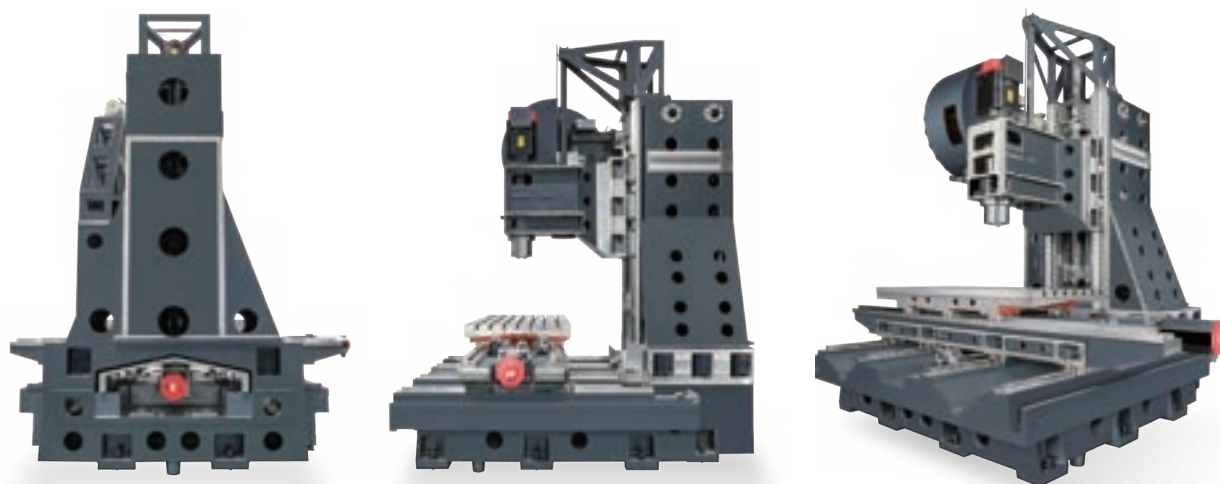

Column Hhydraulomechanics

Server motor directly transmits with ball-type lead screw.

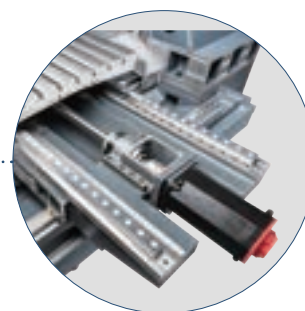

KMC-168CE

1. The three axis transmission system adopts three designs: motor board with cooling oil circuit, cooling system in bearing seat, inner-cooled ballscrew, etc. The purpose is to take away the heat generated by the transmission system in the most effective way to improve the mechanical accuracy.
2. The sharing rate of three axis transmission mechanism reaches 96%.
3. Three axis servo motor and ballscrew with diameter of $\varnothing 50\text{mm}$ transmit directly, with good accuracy.
4. Three axes adopt precision (P) roller-type linear guide ways
5. All three axes are equipped with roller-type linear guide ways, and the long-span design between rails can effectively improve the stability of load support and speed up the reaction speed during processing.
6. Three Axes sliders are configured as 6/8/6 sliders.

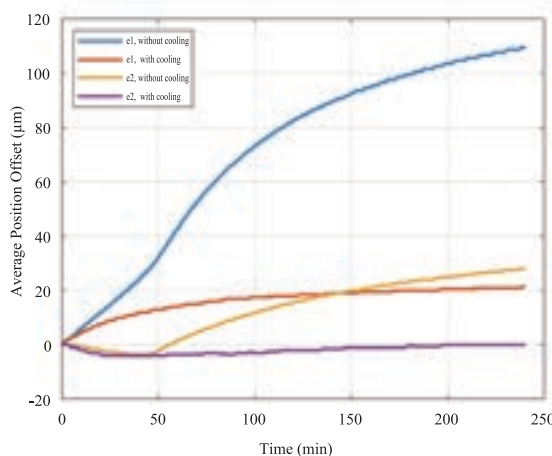

Measuring Condition	
Console	KMC-168CE
Axis Direction	Y Axis
Warm-Up Procedure	Cold Start (Except the necessary laser erection)
Feed Speed Rate	5000 mm/min
Measurement Point Position	-5 (Point 1), -755 (Point 2) [Machine Coordinate]
Pass Stroke	5 mm
Measuring Equipment	Renishaw ML-10

Temperature Rising Offset Data of Cooling System			
Y Axis Feed Rate: 5000 mm/min Target Stop Time: 4 sec Duration Time: 240 min	Max. Scope of Average Position Offset		
	Without ballScrew Cooling	With ballScrew Cooling	Change Percentage
Target Position 1 (Y =-5)	109.5 µm	21.5 µm	80.37 %
Target Position 2 (Y =-755)	31.5 µm	4.0 µm	87.30 %
Ambient Temperature	20.44~20.88° C	19.72~20.74° C	

Source: Precision Machinery Research & Development Center

KMC-CE series

High-Strength Spindle Head

KMC-CE Series Spindle Head

1. CE series direct drive spindle adopts high-precision bevel ball bearings and is lubricated by special grease, which can effectively control the heat output.
2. High-rigidity spindle head structure, which has the best stability in high-speed cutting, ensuring meticulous surface processing effect.
3. Direct drive spindle can prevent mechanical noise, backlash and vibration, and improve processing efficiency and quality.



KMC-168CE

Nitrogen Oil Pressure Weight System

1. In terms of energy saving and environmental protection, KMC-168CE uses nitrogen oil pressure weight system and gas-to-pine clamping system to replace oil pressure unit, aiming at reducing environmental pollution and energy consumption.



Nitrogen Oil Pressure Weight



Oil Box Visualization Design

24-tool disc tool magazine

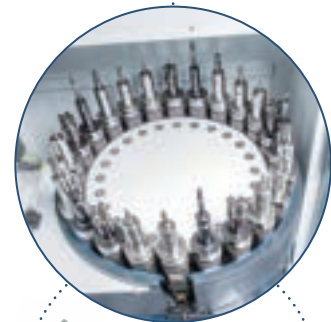
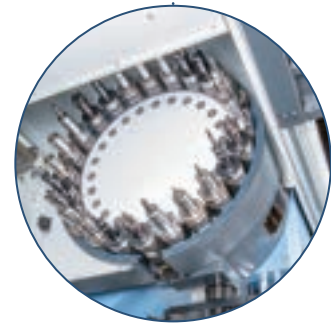
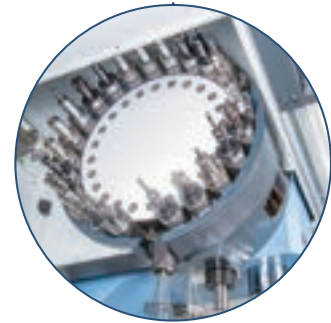

KMC-115CE

1. The 24-tool disc tool magazine is adopted, and cam drive control is adopted.
2. ATC automatic tool changer system, which is quick and reliable.
3. The tool change is fast and smooth, and the tool change is only 1.8 seconds from tool to tool.
4. Tool selection method: Two-way shortcut tool selection.

KMC-136CE

1. The 24-tool disc tool magazine is adopted, and cam drive control is adopted.
2. The 36-tool disc tool magazine is optional, and cam drive control is adopted.
3. The general side locking is improved, and the tool magazine rack is designed to be locked at the bottom, so as to strengthen the stability of the machine during processing.
4. ATC automatic tool changer system, which is quick and reliable.
5. The tool change is fast, and the tool change is only 1.8 seconds from tool to tool.
6. Tool selection method: Two-way shortcut tool selection.

KMC-168CE

1. The 24-tool disc tool magazine is adopted, and cam drive control is adopted.
2. 32-Tool and 40-tool chain-type tool magazine can be selected. The chain tool magazine is driven by electric motor.
3. The general side locking is improved, and the tool magazine rack is designed to be locked at the bottom, so as to strengthen the stability of the machine during processing.
4. ATC automatic tool changer system, which is quick and reliable.
5. The tool change is fast and smooth, and the tool change is only 1.8 seconds from tool to tool.
6. Tool selection method: Two-way shortcut tool selection.

KMC-CE series

Automatic Tool Changer System



bottom lock

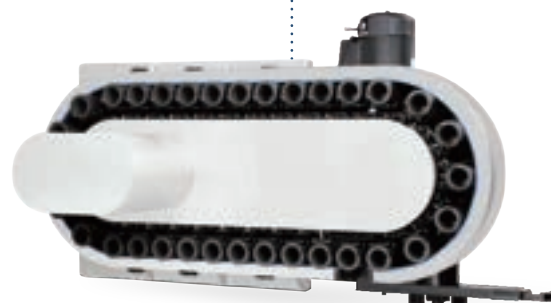

Chain-Type Tool Magazine

	KMC-115CE	KMC-136CE	KMC-168CE
Max. Tool Diameter	ø75	ø75/ø150 (Interval Tools)	ø75/ø150 (Interval Tools)
Max. Tool Length	350mm	300mm	350mm
Max. Tool Weight	7kg		

KMC-CE series

Floor space Diagram and Working Table Dimension Diagram

KMC-115CE

Unit: mm

Working Table Dimension

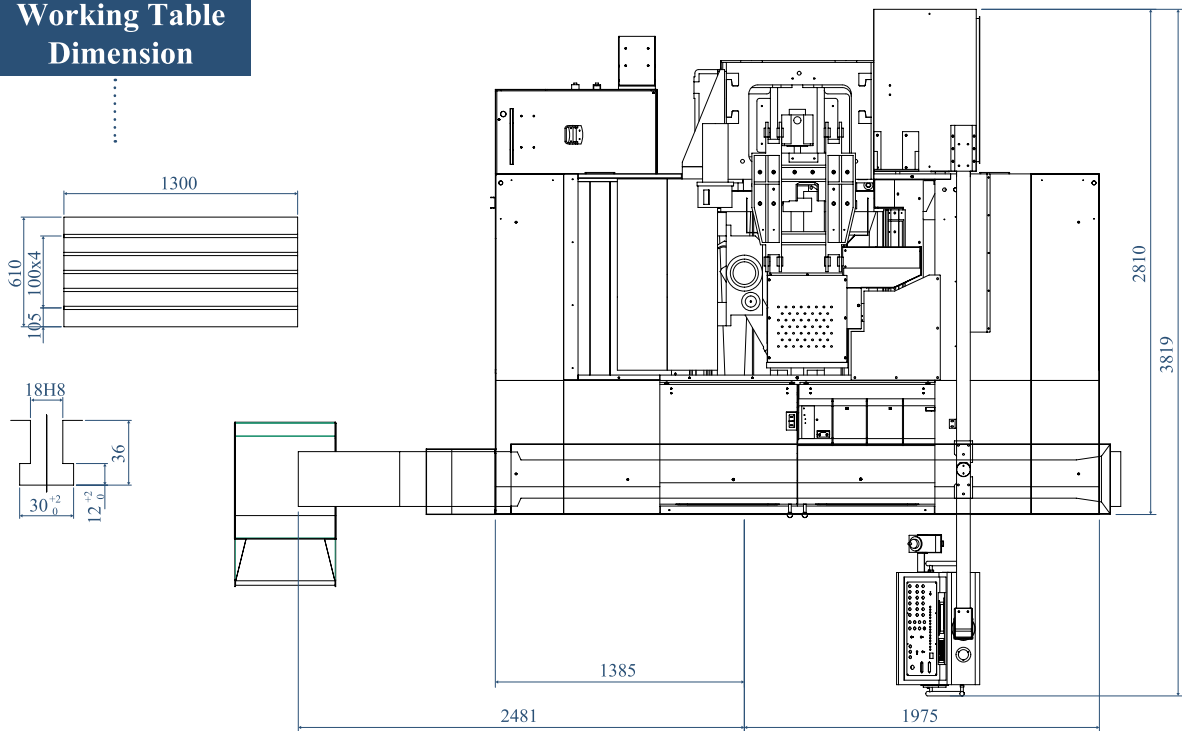

Floor space

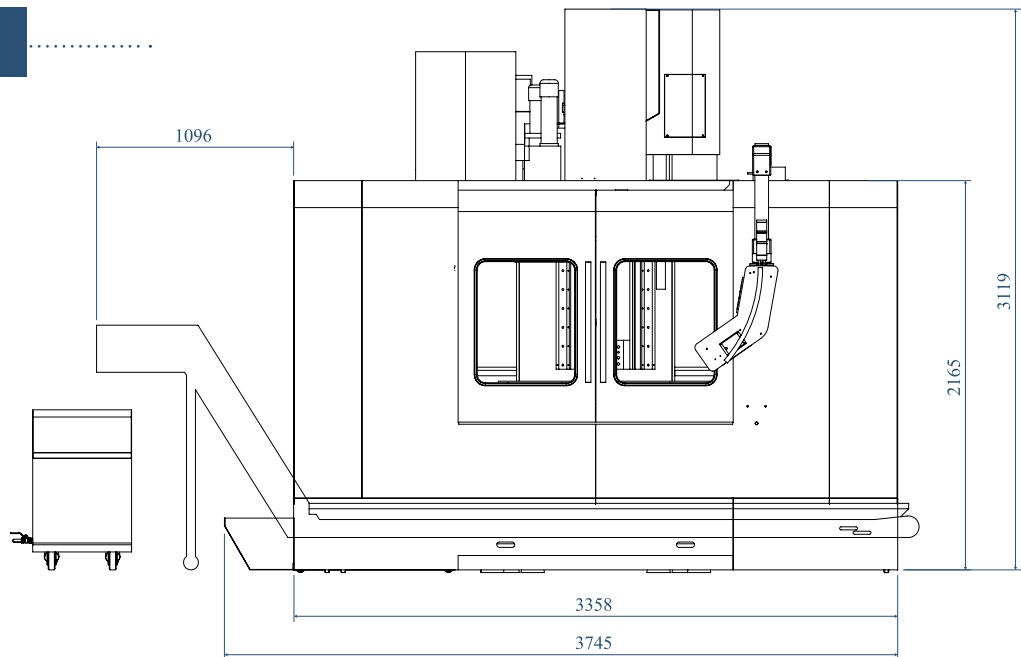

KMC-136CE

Unit: mm

Working Table Dimension

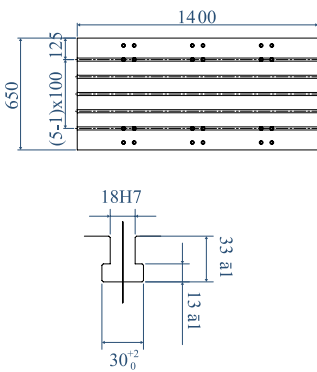

Floor space

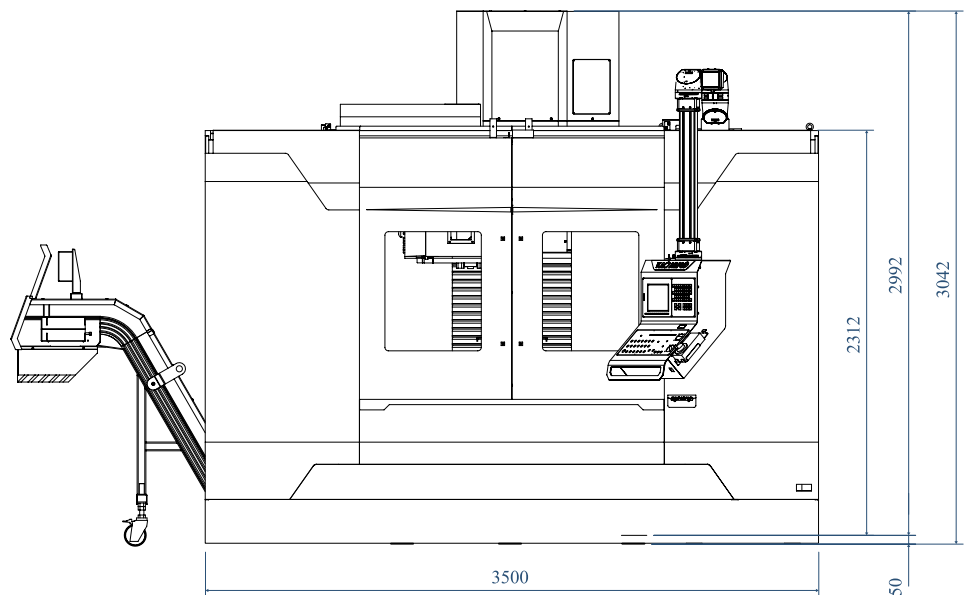
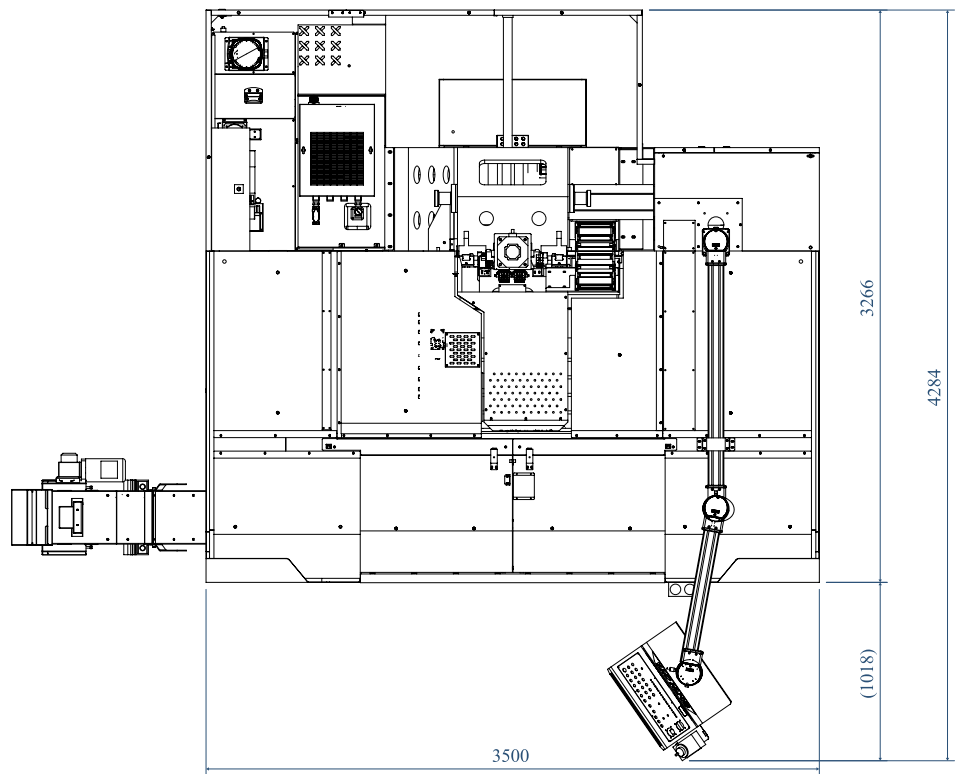

KMC-CE series

Floor space Diagram and Working Table Dimension Diagram

KMC-168CE

Unit: mm

Working Table Dimension

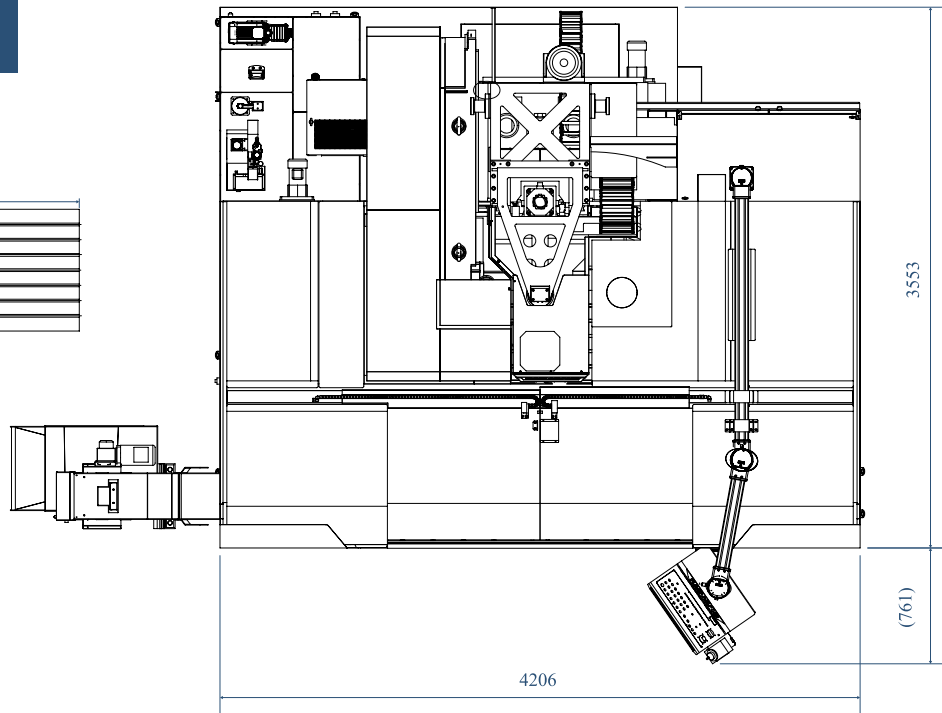
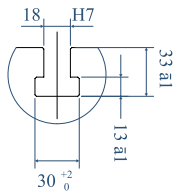
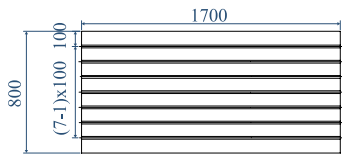

Floor space

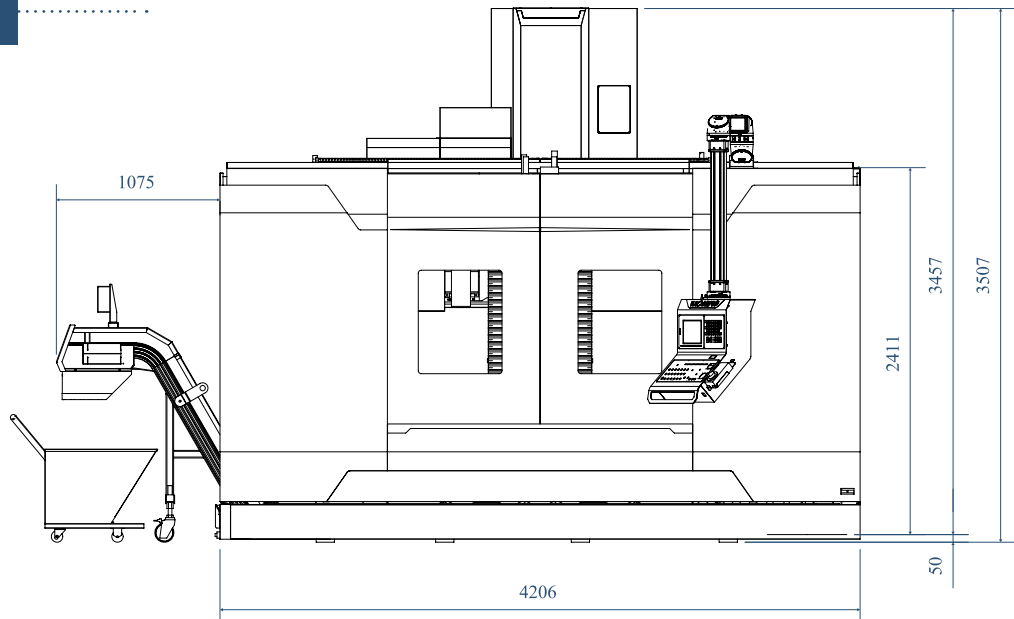

KMC-CE series

Torque Diagram

KMC-115CE

FANUC ai1 12/12000
11/15KW(15/20HP),12000rpm
CTS:unavailable

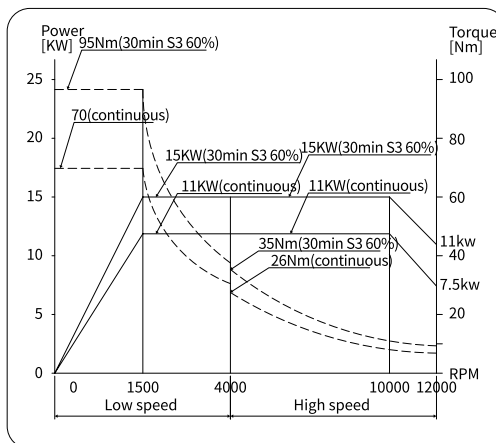

KMC-136CE

FANUC ai1 12/12000
11/15KW(15/20HP),12000rpm
CTS:unavailable

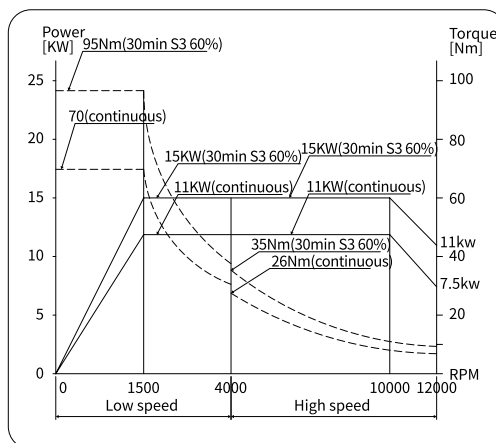

KMC-168CE

MOTOR : FANUC ai1 15/10000
15/18.5KW(20/25HP),10000rpm
CTS:unavailable

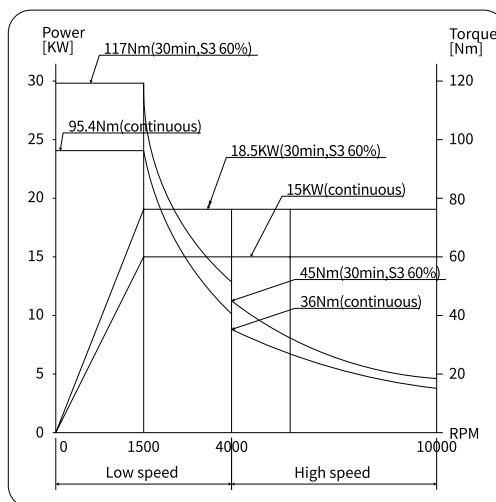

II

K M C - C H s e r i e s



KMC-CH series

Console Main Features

1. The main castings are made of high-grade Meehanite cast iron, with strong rib strengthening design and rigidity characteristics. When processing at high speed, it highlights its extraordinary stability.
2. Extra-wide four-slide base.
3. Gear type two-stage variable speed spindle, suitable for heavy cutting.
4. Three axes square box way.
5. Intelligent operation platform (IPROS MX) can be set to improve the operation process. It is an innovative vertical machining center machine with great economic benefits.

KMC-116CH



KMC-158CH

KMC-CH series

High-Rigidity Structure and High-Positioning Accuracy

Four-slide with rigid structure base

1. Extra-wide four-slide base with box way span of 1420mm (KMC-158ch)/1200mm (KMC-116CH) can bear heavy load on average, and it can be processed smoothly to ensure accuracy.
2. The main castings are made of high-grade MEEHANITE cast iron, combined with strong rib structure, which has excellent rigidity and is suitable for heavy cutting.
3. All the three axes are fully supported by square box way within the effective stroke, and there will be no phenomenon of overhanging and sagging.
4. The hardened and grinded slide, which is the best choice to realize precision heavy cutting, uses the fluorine resin (TURCITE-B) with strong wear resistance and vibration absorption as the sliding medium.



Precision Scraping

1. KAOMING has unique and excellent geometric accuracy. The important factors include the machine structure and precision machining of castings, and more importantly, our company has ingenious scraping personnel. The scraping personnel have rich experience, and with rigorous and dedicated working attitude, they create the best verticality, flatness and smoothness of movement of the structure. In the process of scraping, we use precision testing instruments to calibrate the geometric accuracy of the machine to the highest standard.

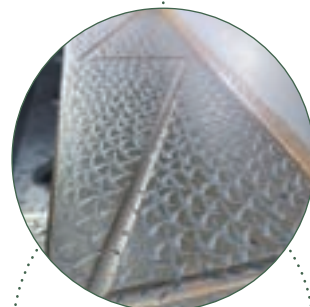

KMC-CH series

High-Strength Spindle Head

1. Adopt 11/15KW (158CH with optional 15/18KW) spindle motor and gear-type two-steps spindle, with the 4400 rpm (optional 6000 rpm, 7000 rpm and 8000 rpm).
2. Spindle adopts high-precision bevel ball bearings and is lubricated by special grease, which can effectively control the heat output.
3. The spindle cooling system with forced cooling oil circulation is adopted outside the spindle and inside the gear box to effectively control the temperature rise and restrain the thermal deformation.
4. The special design of floating tool-withdrawing hydraulic cylinder is adopted, so that the spindle bearing is completely stress-free during tool withdrawal.
5. The spindle head counterweight is equipped with a guide and safety protection device.
6. Optional manual universal head (optional accessories), which can be widely processed.
7. Optional coolant through spindle center system (optional accessories), provide 600L large capacity coolant tank and medium and high pressure pump, and double filter cooling system can effectively cool cutting tools and improve machining accuracy.

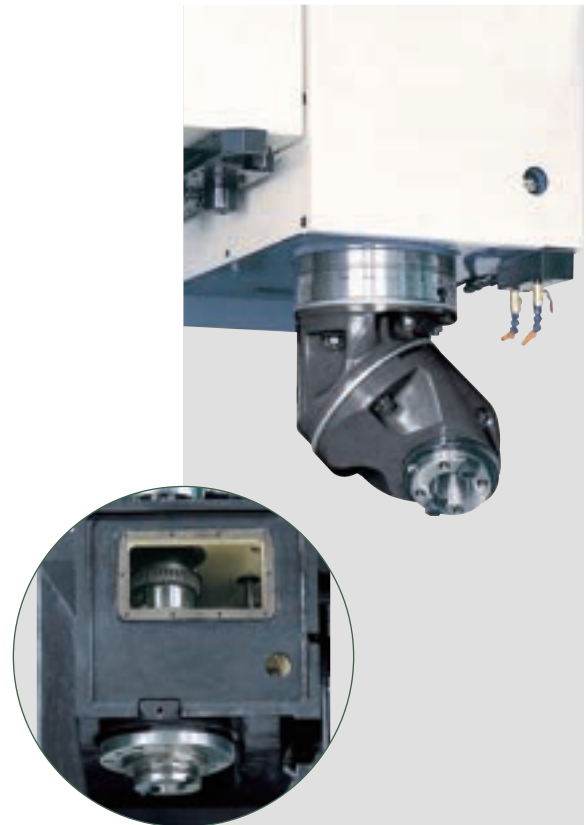

KMC-CH series

High-Speed Module Processing

Three Axes Feed System



1. Three Axes servo motor and ballscrew drive directly, with good accuracy.
2. The two ends of a ballscrew with a diameter of $\varnothing 50\text{mm}$ are supported by heavy-duty bevel ball bearings; Pre-loading bearing and pre-tensioning ballscrew ensure the rigidity and accuracy.

KMC-CH series

Automatic Tool Changer System

KMC-116CH

1. The 24-tool disc tool magazine is adopted, and cam drive control is adopted.
2. ATC automatic tool changer system, which is quick and reliable.
3. The tool change is fast and smooth, and the tool change is only 3.7 seconds from tool to tool.
4. Tool selection method: Two-way shortcut tool selection.

24-tool disc tool magazine



KMC-158CH

1. 32-Tool chain-type tool magazine can be adopted. The chain tool magazine is driven by electric motor.
2. 40-Tool chain-type tool magazine can be selected. The chain tool magazine is driven by electric motor.
3. ATC automatic tool changing system, which is quick and reliable.
4. The tool change is fast and smooth, and the tool change is only 3.7 seconds from tool to tool.
5. Tool selection method: Two-way shortcut tool selection.

Chain-Type Tool Magazine



	KMC-116CH	KMC-158CH
Max. Tool Diameter	ø105	ø125
Max. Tool Length	300mm	350mm
Max. Tool Weight	15kg	

KMC-CH series

Floor Space Diagram and Working Table Dimension Diagram

KMC-116CH

Unit: mm

Working Table Dimension

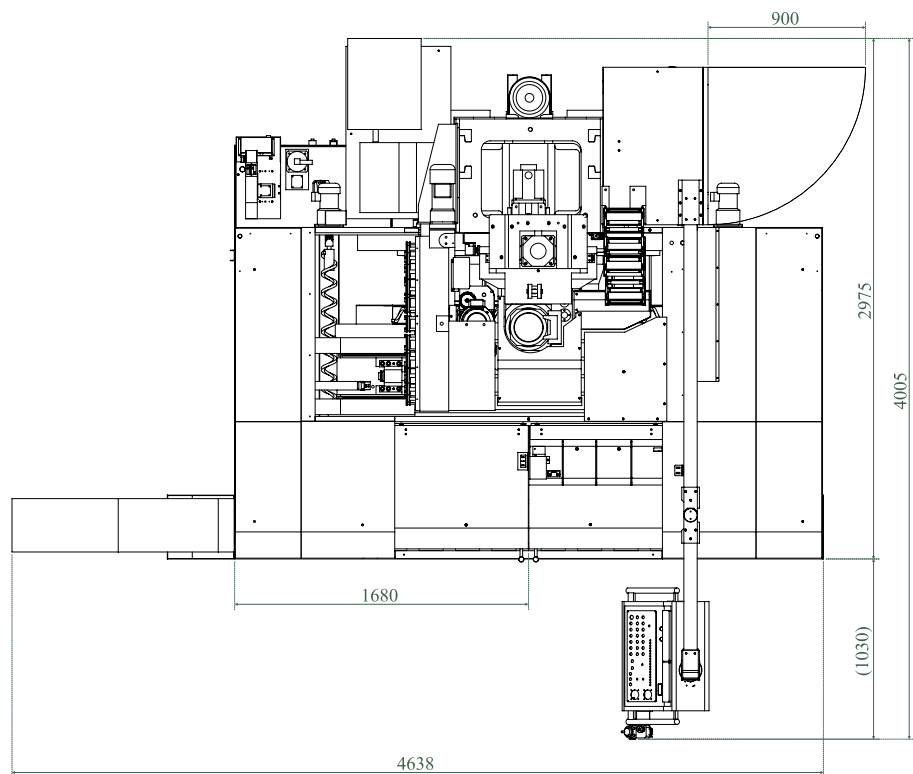
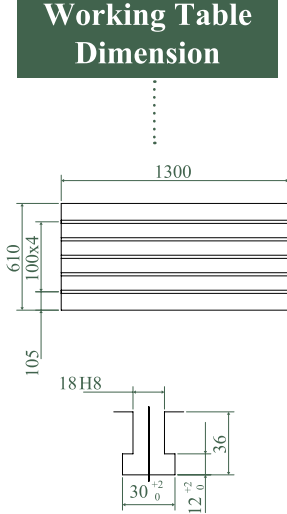

Floor space

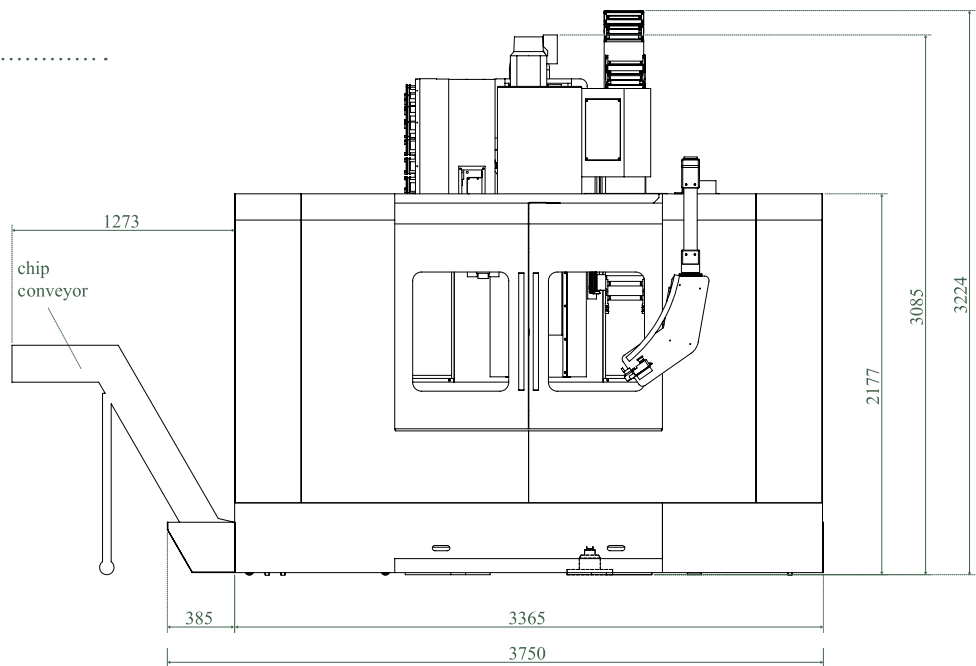

KMC-CH series

Floor Space Diagram and Working Table Dimension Diagram

KMC-158CH

Unit: mm

Working Table Dimension

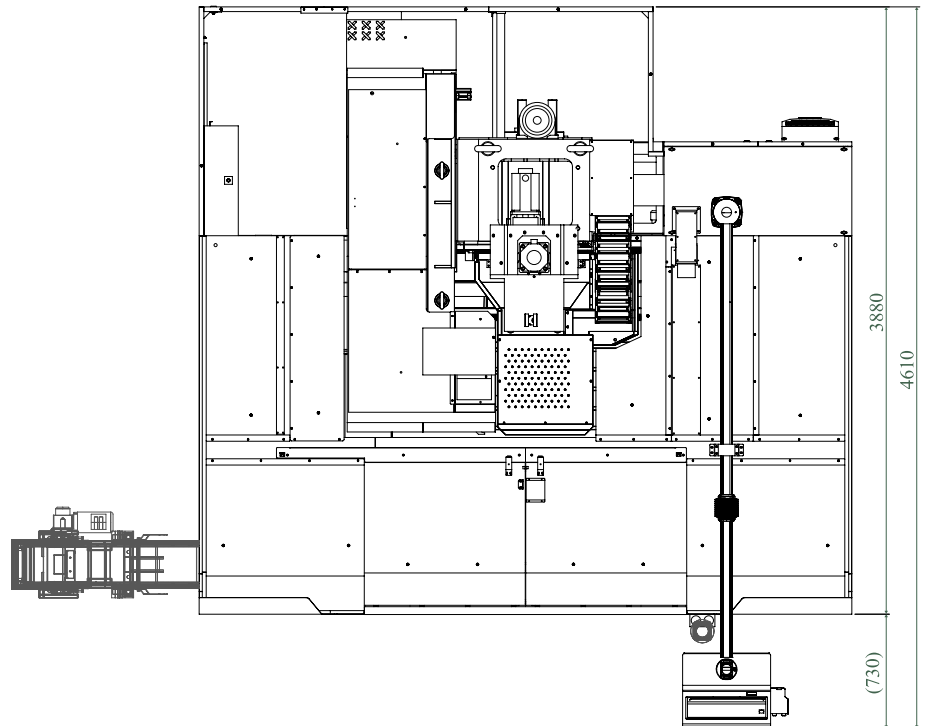
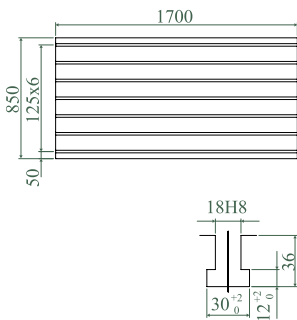

Floor space

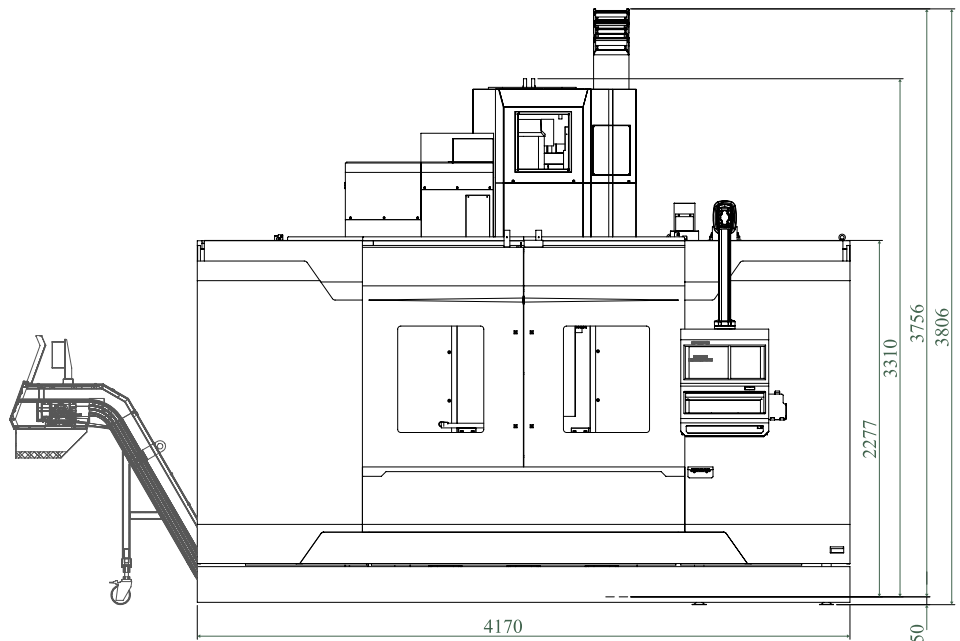

KMC-CH series

Torque Diagram

KMC-CE series

KMC-116CH

aiI 12/12000
11/15K W(15/20HP), 4400RPM

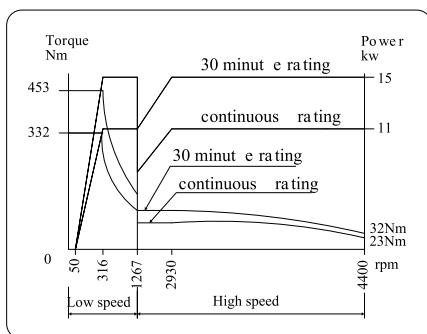

aiI 12/12000
11/15K W(15/20HP), 6000RPM

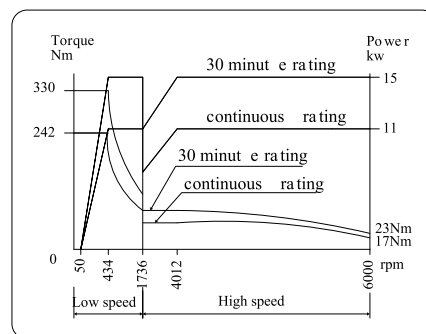

KMC-158CH

MOTOR: aiI12
11/15K W(15/20HP),4400RPM

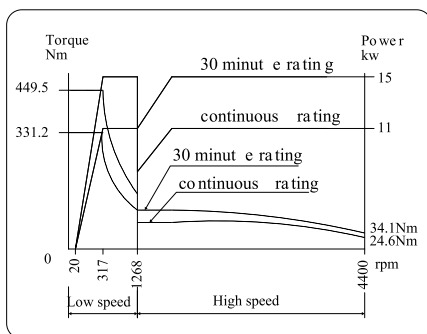

MOTOR: aiI15
15/18.5K W(20/25HP),4400RPM OPT.

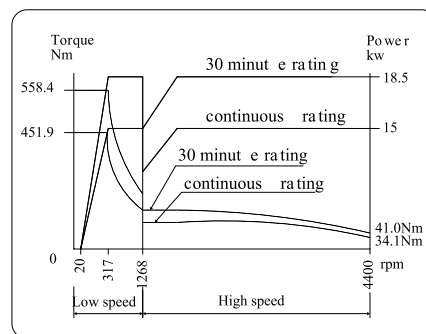

MOTOR: aiI12
11/15K W(15/20HP),6000RPM OPT.

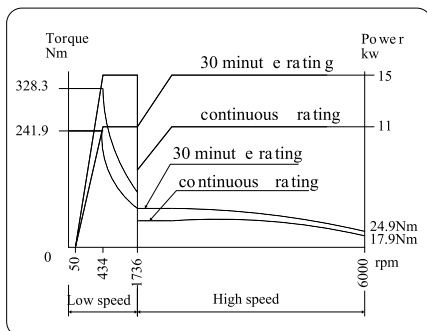

MOTOR: aiI15
15/18.5K W(20/25HP),6000RPM OPT.

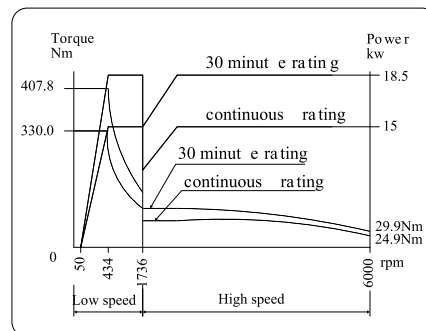

KMC-CH series

KMC-CE&CH

Machine Specification Table of KMC-CE&CH Series

Item		KMC-115CE	KMC-136CE	KMC-168CE	KMC-116CH	KMC-158CH
Travel	X-Axis travel (mm)	1100	1300	1600	1100	1530
	Y-Axis travel (mm)	550	650	800	610	850
	Z-Axis travel (mm)	610	650	800	610	800
	Distance from spindle nose to working table (mm)	100-710	100-750	100-900	150-760	200-1000
	Distance from spindle center to column surface (mm)	650	800	950	650	850
Working Table	Working Table Dimension (mm)	1300*610	1400*650	1700*800	1300*610	1700*850
	Max. Load Weight (kg)	1200	1300	1700	1200	2200
	T-Slot (mm)	18*5*100		18*7*100	18*5*100	18*7*125
Spindle	Spindle Taper	BT-40	BBT-40	BBT-50	BT-50	
	Spindle Speed (rpm)	12000		10000	4400(*6000,*7000,*8000)	
	Spindle Speed Conversion	Direct-Type			Gear-type, two-gear, non-stage variable speed	
	Spindle Motor	AC 11/15KW (15/20HP) (cont./30min)		AC 15/18KW (20/25HP) (cont./30min)	AC 11/15KW (15/20HP) (cont./15min)	AC 11/15KW (15/20HP) (cont./30min) (*AC 15/18KW (20/25HP) (cont./30min))
Feed	Feed rate (X, Y, Z)	(18,18,15)	(36,36,36)	(32,32,32)	(15,15,12)	
Tool Magazine	Tool Magazine Capacity	24	24 (*36)	24 (*32,*40)	24	32 (*40)
	Tool taper	BT-40	BBT-40 (*BT-40)	BBT-50 (*BT-50)	BT-50	
	Max. Tool Diameter (mm)	ø75	ø75 / ø150		ø105	ø125
	Max. Tool Length (mm)	350	300	350	300	350
	Max. Tool Weight (kg)	7			15	
	Tool Selection Method	Two-way shortcut tool selection				
	Time of Tool Switching (sec.)	1.8			3.7	
Mechanical Dimension	Mechanical Height (mm)	3119	3042	3507	3224	3806
	Mechanical Weight (kg)	10000	8000	15000	10000	14000
	Land Area (mm)	3745*3819	3500*4284	4206*4314	3750*4005	4170*4610
Accuracy	Positioning Accuracy (mm)	±0.005/ full travel	±0.003/ full travel		±0.005/ 300mm	
	Repeat Accuracy (mm)	±0.003				
Connection Power (KVA)		35	45	50	35	45
Controller		FANUC series (*HEIDENHAIN *SIEMENS series)				

Standard Accessories & Special Accessories of KMC-CE&CH Series

Item		KMC-115CE	KMC-136CE	KMC-168CE	KMC-116CH	KMC-158CH
● Standard Accessories, ○ Special Accessories						
1	Cooling Pump Device	●	●	●	●	●
2	Centralized Automatic Lubricating System	●	●	●	●	●
3	Fully enclosed Sheet Metal	●	●	●	●	●
4	Tool for Adjustment (1 Set)	●	●	●	●	●
5	Operation/Maintenance Manual and Appliance Diagram (1 Set)	●	●	●	●	●
6	Foundation Bolt and Horizontal Adjustment Bolt (1 Set)	●	●	●	●	●
7	Working Light	●	●	●	●	●
8	Spindle Cooling Machine	●	●	●	●	●
9	Alarm Light	●	●	●	●	●
10	Blowing Device	●	●	●	●	●
11	Automatic Power-Off Function	●	●	●	●	●
12	Finished Light	●	●	●	●	●
13	Transformer (except 220V power supply)	●	●	●	●	●
14	Rigidity Tapping	●	●	●	●	●
15	Link-Type chip Conveyor	○	○	○	○	○
16	Scraper-Type chip Conveyor	○	○	○	○	○
17	Dual-Type chip Conveyor	○	○	○	○	○
18	CAT, DIN, ISO Tool Handle	○	○	○	○	○
19	Spray Cooling Device	○	○	○	○	○
20	Oil Hole Drill Bit Interface	○	○	○	○	○
21	Linear scale	○	○	○	○	○
22	Automatic Tool Length Measuring System	○	○	○	○	○
23	Automatic touch Probe System	○	○	○	○	○
24	Coolant through spindle center (A & B type)	○	○	○	○	○
25	NC Rotation Table	○	○	○	○	○
26	Manual Universal Head	-	-	-	○	○
27	Intelligent Operation Platform (IPROX MX)	○	○	○	○	○
28	Intelligent Temperature Control System (Spindle Temperature Auxiliary System)	○	○	○	○	○

Conveyor

This series can be equipped with link-type chip conveyor, scraper-type chip conveyor and dual-type chip conveyor.

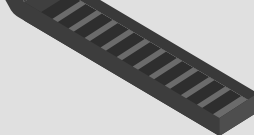
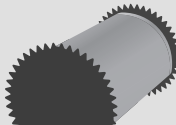
		Iron chip	Metal chip	Non-rolled chip	Cast iron chip	Aluminum chip
	link-Type chip Conveyor	✓	✓			
	Scraper-Type chip Conveyor			✓	✓	✓
	Dual-Type chip Conveyor	✓	✓	✓	✓	✓

KMC-CH series

KMC-CH series

KMC-CE&CH

Intelligent Operation Platform

This series can be equipped with an intelligent operation platform (IPROS MX) beside the original controller platform. This intelligent operation platform can provide 19 intelligent functions to equipment users, aiming at improving the operation process efficiency of equipment users and enhancing the interaction between people and equipment.



Intelligent Temperature Control System

This series can be equipped with intelligent temperature control system (spindle temperature auxiliary system), which adopts external device beside the machine. This device can quickly make the machine enter the thermal steady state, effectively control the cooling speed, make the spindle accuracy change very little, and provide faster and more effective temperature, accuracy, thermal deformation and other issues.

1	Intelligent Spindle Diagnosis System
2	Intelligent Peripheral System Diagnosis Function
3	Intelligent Maintenance Function
4	Intelligent Axial Backlash Detection Function
5	Digital Machining Information Display Function
6	Intelligent Fault Alarm Elimination Function
7	Schedule Display Management Function
8	Automatic Work Report Function of Single Machine
9	SPC Function of Returning Production Quality
10	Management Function of Production Rate of Single Machine
11	Energy Management Function of Single Machine
12	Intelligent Processing Calculator
13	Thermal Displacement Control Solution
14	Process Monitoring and Recording Function
15	Cutting Liquid Quality Monitoring Management Function
16	Intelligent Regular/Remote Warm-Up Function
17	Intelligent Promotion Function of Single Machine
18	Remote Diagnosis Service
19	Intelligent Built-In Camera Function

Make same to different



Kao Ming Machinery Industrial Co.ltd

<http://www.kaoming.com>

CTSP Branch (Communication Division)

TEL +886-4-25577650 FAX +886-4-25577630

km@kaoming.com.tw

53,Houke S Rd.,Houli Dist,Taichung City 42152, TAIWAN