



Taiwan TAKISAWA Technology Co., Ltd.

www.takisawa.com.tw

Pingchen No.505, Sec. 3, Yenping Rd., Pingchen Dist., Taoyuan City 324, Taiwan.
TEL : +886-3-4643166 FAX : +886-3-4642614
Yangmei No.85, Sec. 1, Meishi Rd., Yangmei Dist., Taoyuan City 326, Taiwan.
TEL : +886-3-4813119 FAX : +886-3-4813185
E-mail : callcenter@takisawa.com.tw

Shanghai TAKISAWA Mechatronics Ltd.

Shanghai No.1568, Yuanguo Rd., Anting Town, Jiading Dist., Shanghai.
TEL : +86-21-59562955 FAX : +86-21-59562956

Dealer

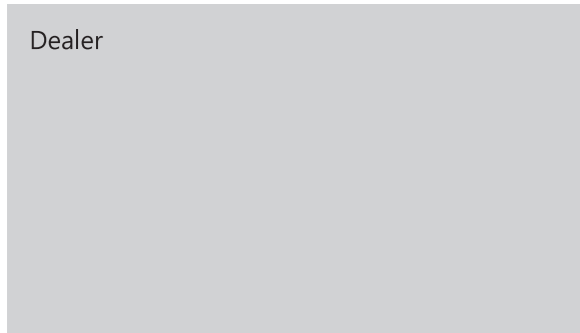

2020.05



LA-150 Series

LA-150 · LA-150L · LA-150M · LA-150ML

LA-200 · LA-200L · LA-200M · LA-200ML

LA-200 Series

LA-150 | LA-200 Series

Variety of modle configurations, Box guide way for all guide rails
 Taiwan Takisawa home-made turret and spindle provide high rigidity and high accuracy Minimum footprint,
 maximum working space
 Ready for automation and customisation, Your best choice for high productivity with low investment.



Specification Options

	LA-150[L]	LA-150M[L]	LA-200[L]	LA-200M[L]
T8 Turning Turret	●	---	●	---
T10 Turning Turret	◎	---	◎	---
T12 Turning Turret	◎	---	◎	---
T12 Milling Turret	---	●	---	●
Pin Carry Tailstock	◎	◎	◎	◎
Manual Tailstock	◎	◎	◎	◎

●:Standard ◎:Optional ---:Nope

Workpiece Size

※ Specifications are subject to change without notice.

	LA-150[L]	LA-150M[L]	LA-200[L]	LA-200M[L]	
Max. Turning Diameter	320	250	320	250	mm
Max. Turning Length	328 [628]	313 [613]	300 [600]	284 [584]	mm
Max. Bar Work Capacity Diameter	42	42	52/66	52/66	mm

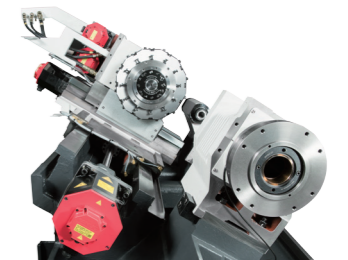
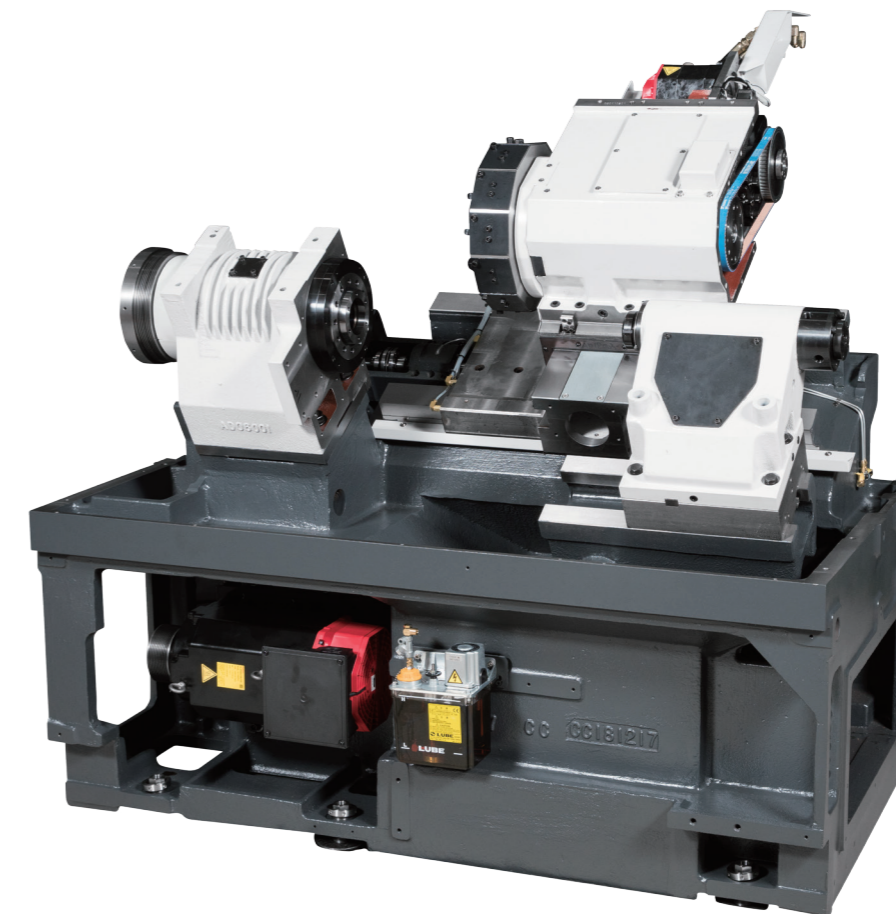

30 degree slant bed design supports high rigidity and less footprint.

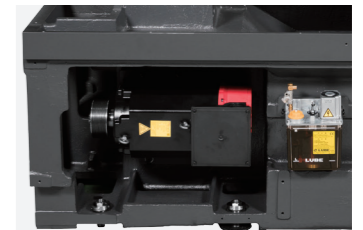

Spindle motor and lubrication tank are located in front of machine, easy to service.

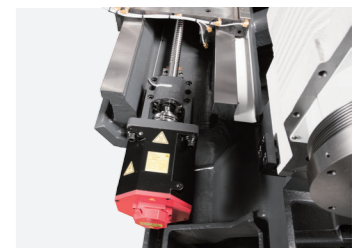

Box guide way design for X and Z axis ensures dynamic rigidity with vibration attenuation to maintain good accuracy in heavy cutting process.

Travel & Rapid Traverse

	LA-150[L]	LA-150M[L]	LA-200[L]	LA-200M[L]	
X-Axis Travel	175	175	175	175	mm
X-Axis Rapid Traverse	24	24	24	24	m/min
Z-Axis Travel	375 [675]	375 [675]	375 [675]	375 [675]	mm
Z-Axis Rapid Traverse	24	24	24	24	m/min

※ Specifications are subject to change without notice.

Spindle

The spindle is made in house to ensure highest quality and reliability, spindle type can be selected according to the requirement of accuracy, torque and cost effective from customer.

Motor, through-hole size, spindle speed ratio and spindle nose can be customised according to the requirement from customer.



Belt driven spindle design is economic and easy to maintain.

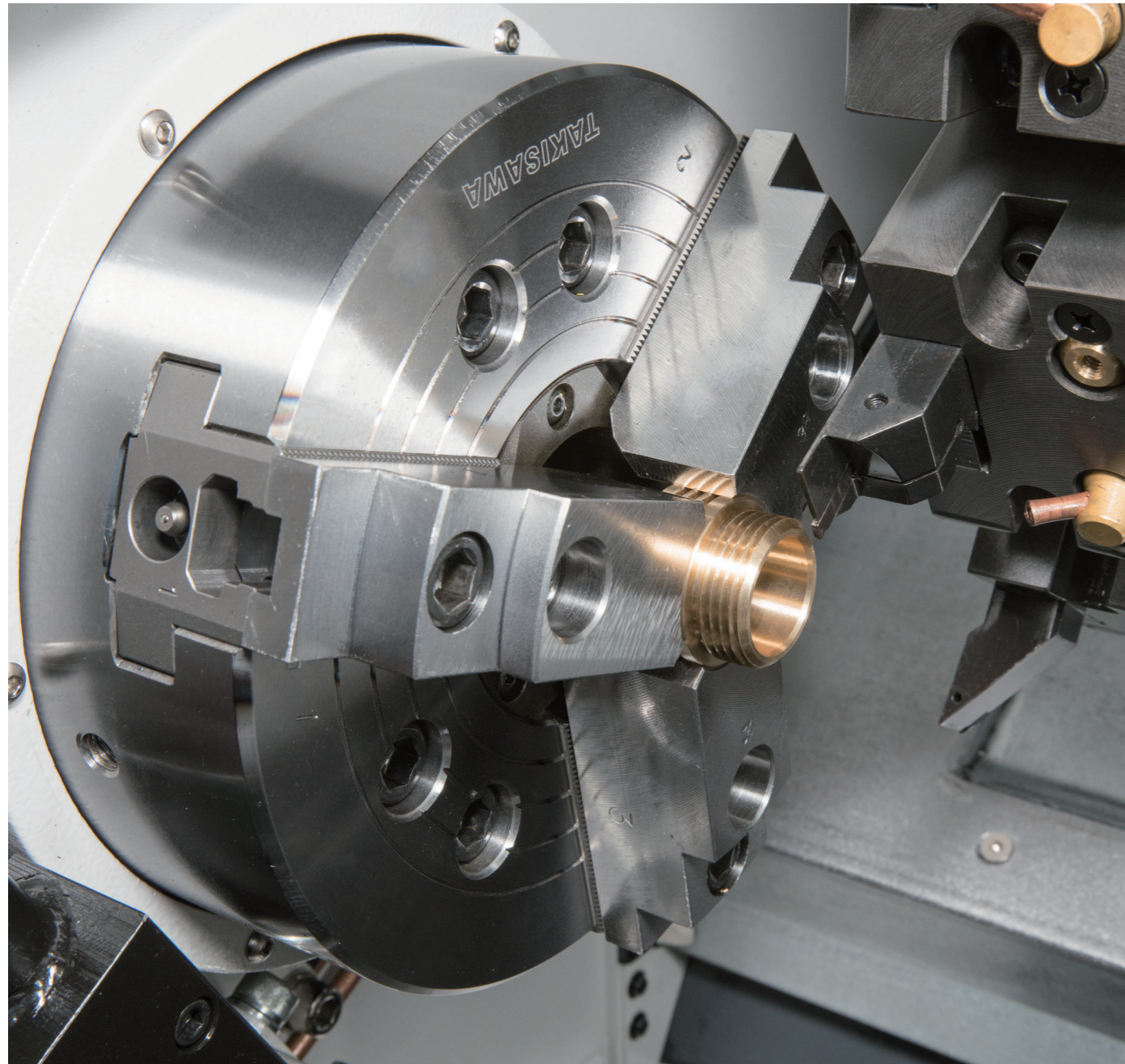

Spindle Output Diagram

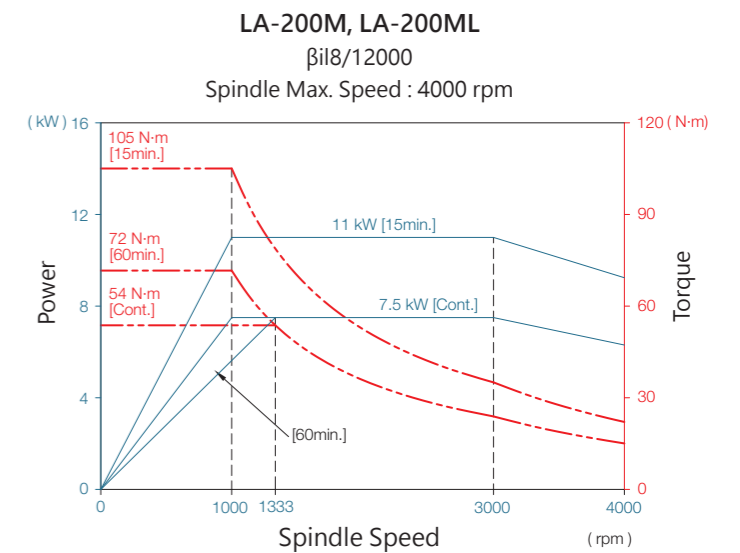
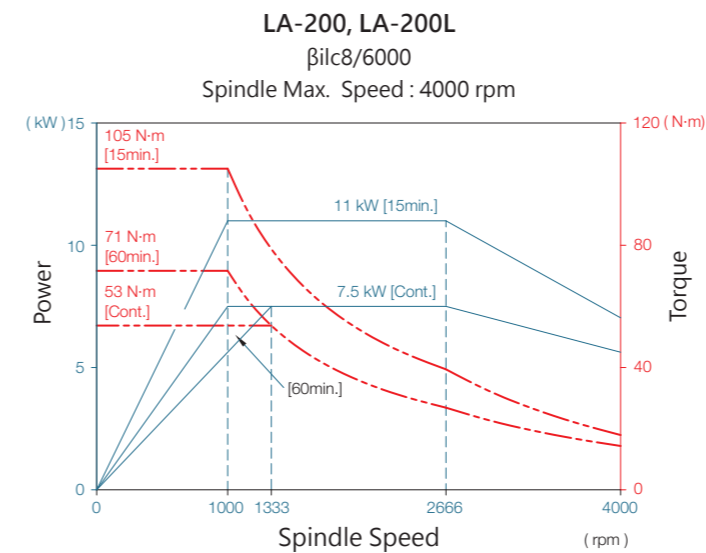
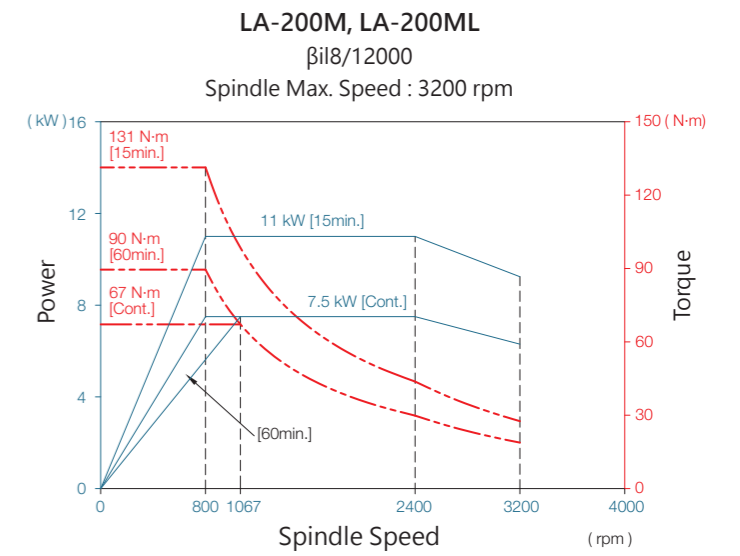
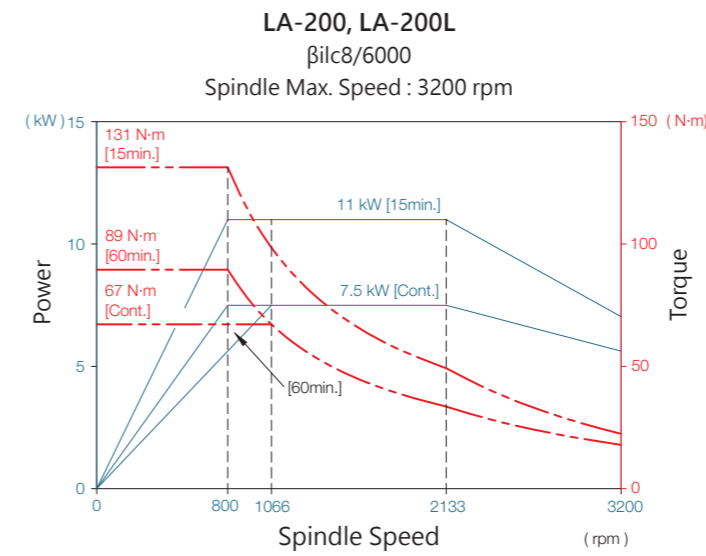
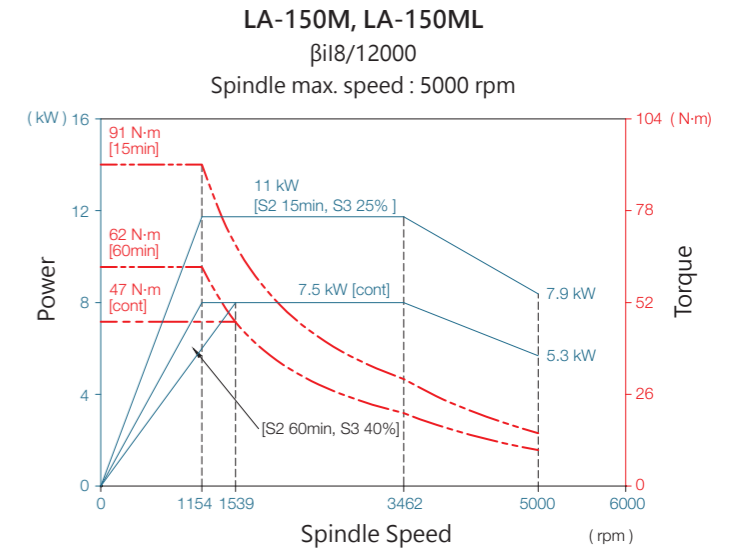
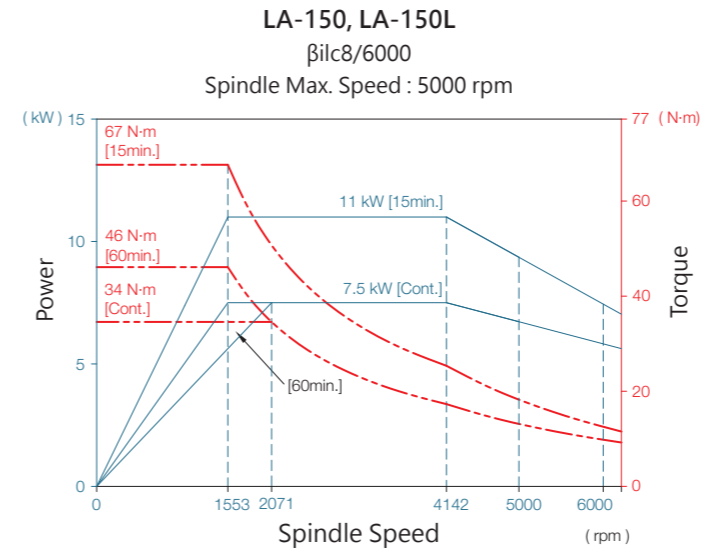

Turret

The T12 Milling Turret is a tested in house design that enables combined machining such as milling, drilling and tapping in addition to conventional turning. This allows complex and highly accurate machining in a single cycle for mass production of parts. We can provide a customised needs assessment for special needs regarding numbers of tools, tool holders, milling cutters etc.

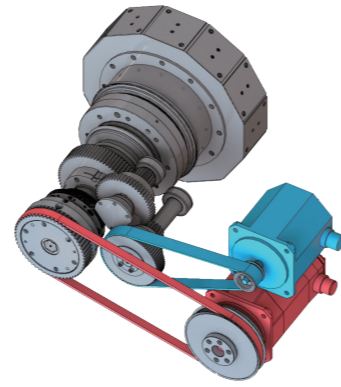

The milling motor is driven by a spindle motor and the tool changer is driven by a servo motor.

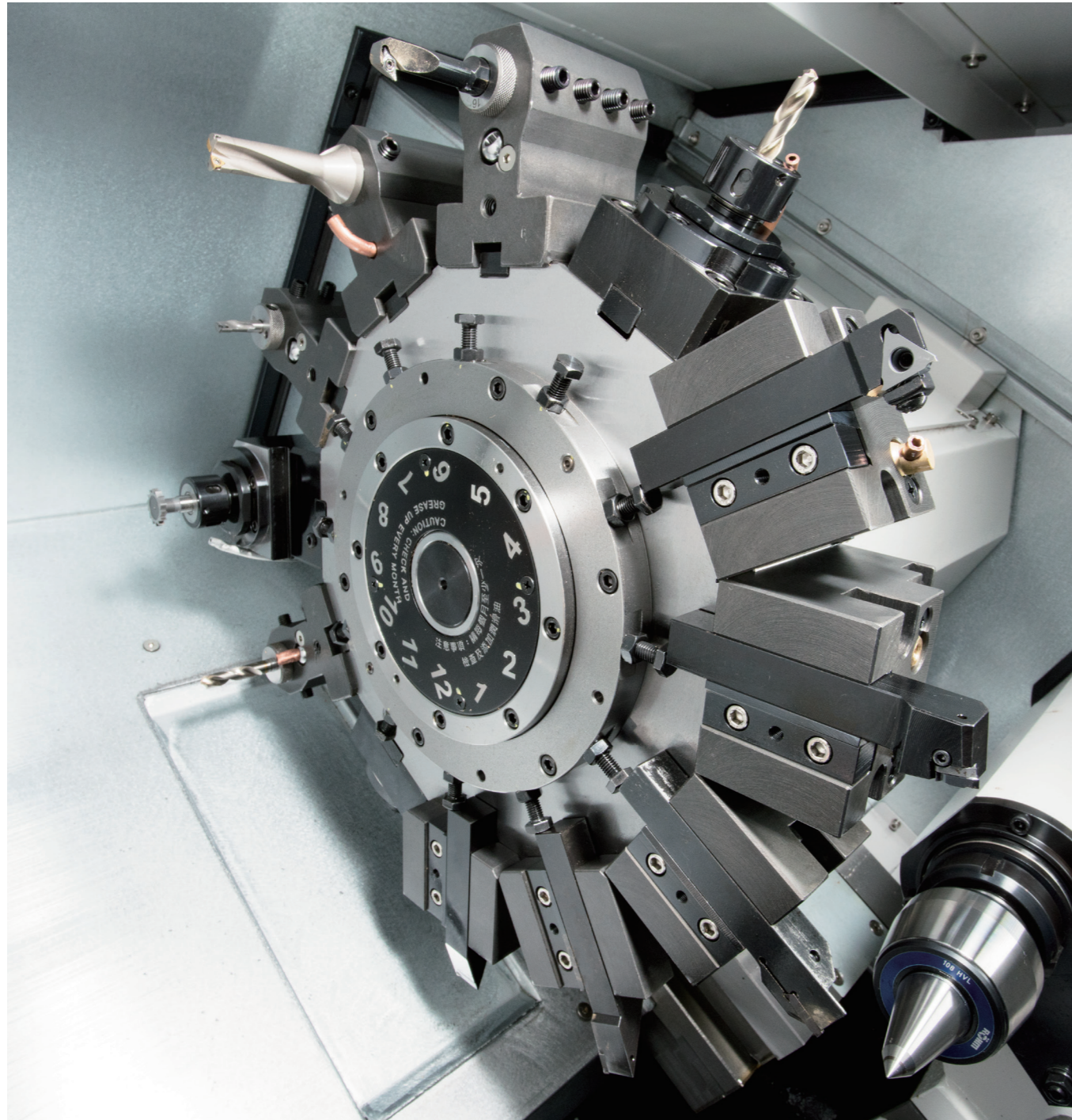

Turret Structure

- 01** Curvic coupling OD 180mm performs high rigidity and accuracy.
- 02** Ready for 70 bar hi-pressure coolant.
- 03** Easy to grease up.

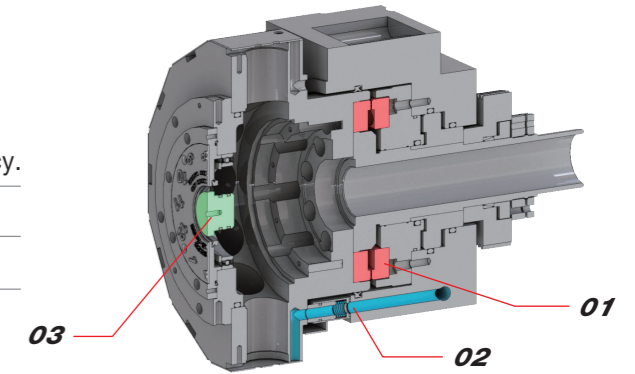

T12 Milling Turret

Number of Tools	12
OD Tool Shank Dimension	20 mm
ID Tool Shank Diameter	25 mm
Milling Shank Diameter	13 mm
Milling Spindle Speed	4000 rpm
Motor Output	2.2 kW
Max. Torque	52 N·m

T12 Turning Turret (Option)

Number of Tools	12
OD Tool Shank Dimension	25 mm
ID Tool Shank Diameter	40 mm

T10 Turning Turret (Option)

Number of Tools	10
OD Tool Shank Dimension	25 mm
ID Tool Shank Diameter	40 mm

T8 Turning Turret (Standard)

Number of Tools	8
OD Tool Shank Dimension	25 mm
ID Tool Shank Diameter	40 mm

Spindle Output Diagram

Milling Spindle Motor : α iS12/6000
Spindle max. speed : 4000 rpm

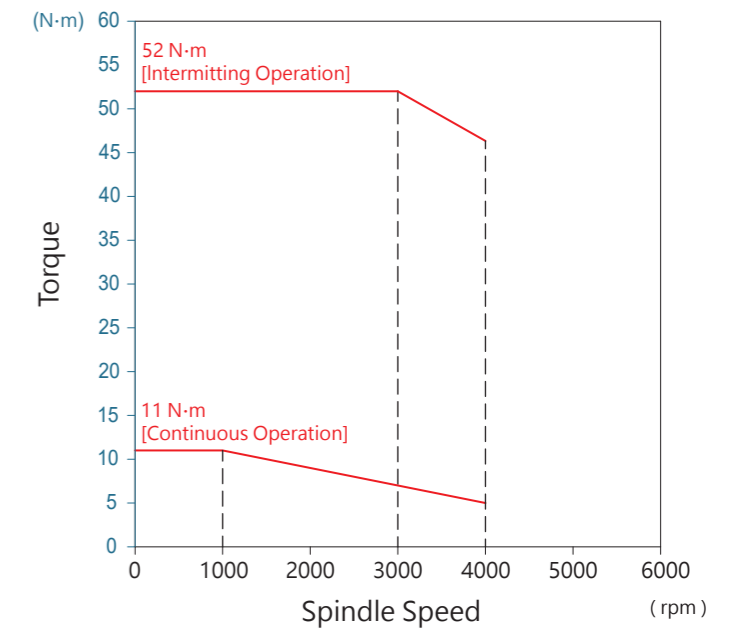

Special Tool Holders

- 01** Gear Hobbing
- 02** Broaching
- 03** Power Skiving
- 04** Adjustable Angle Milling



Tailstock

High rigid tailstock body with hydraulic driven quill, various driven types can be selected according to the requirement of user. High thrust or quill type can be customized according to the requirement of customer.

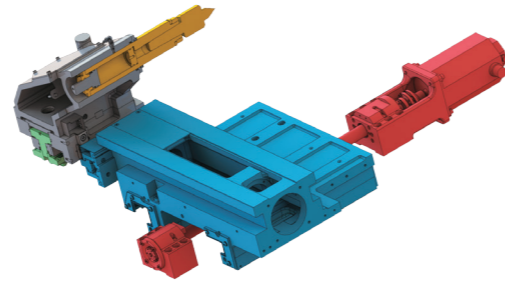

PIN carried tailstock can be quick positioned by Z axis servo motor, working cycle time can be reduced.

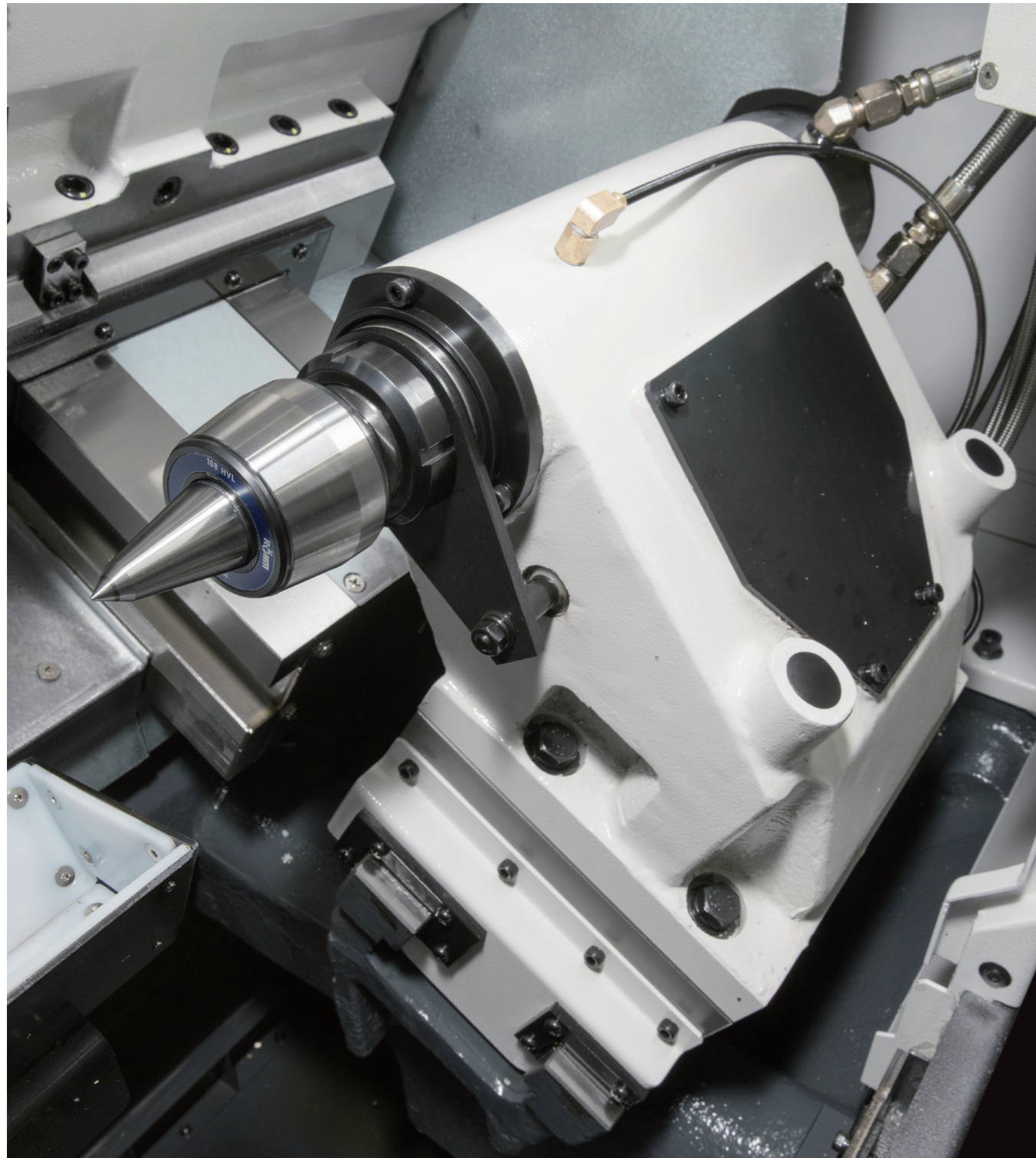

Manual Tailstock (Option)

Tapered Bore Type	MT.4	
Tailstock Spindle Diameter	75	mm
Tailstock Spindle Travel	100	mm
Max. Thrust of Tailstock Spindle	5.8	kN

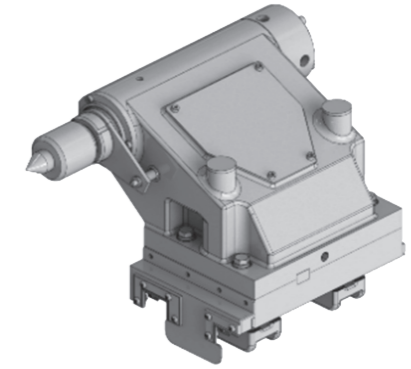

Pin Carry Tailstock (Option)

Tapered Bore Type	MT.4	
Tailstock Spindle Diameter	75	mm
Tailstock Spindle Travel	100	mm
Max. Thrust of Tailstock Spindle	5.8	kN

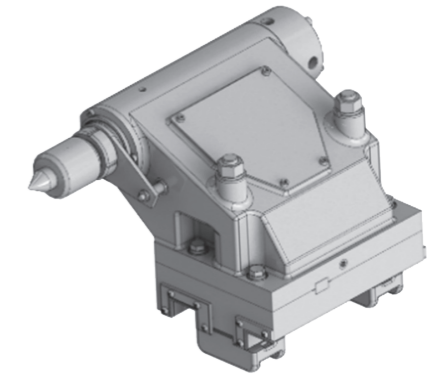

01 Steady Rest

Maintain stable centering for long workpiece machining, optimum machining accuracy.

Hydraulic Steady Rest		
SMW SLU-Z-1	Ø4~Ø64	mm

01

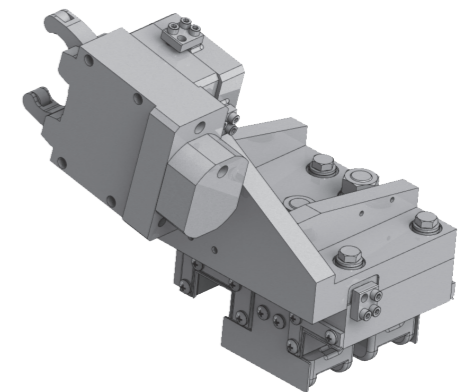

02 Chip Conveyor

To assist with factory layout right and rear side chip conveyors are available.

Hinge Type
Chip Conveyor

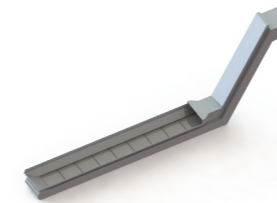

Scraper Type
Chip Conveyor



02

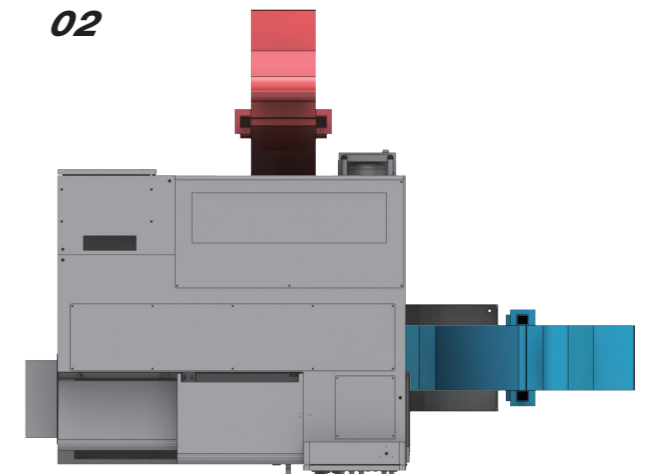

Chip Type	Curly Metallic Chip Steel /Aluminum	Power Metallic Chip Foundry /Aluminum /Brass	Non- Metallic
Hinge Type	○	X	○
Scraper Type	X	○	X

Working Range | Interference Diagram

LA-150[L] T8

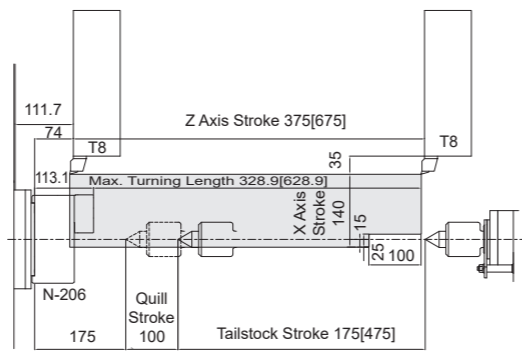
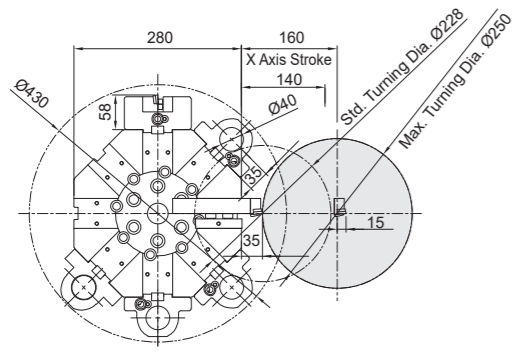

LA-150[L] T12

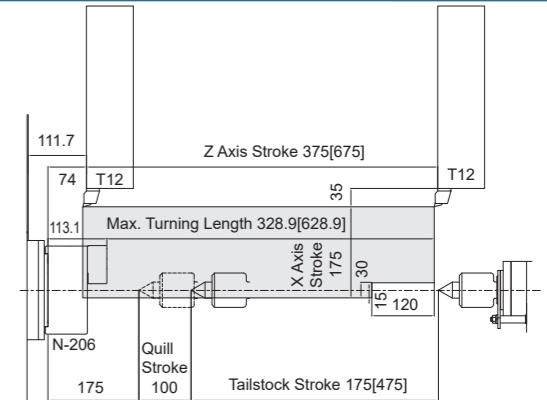
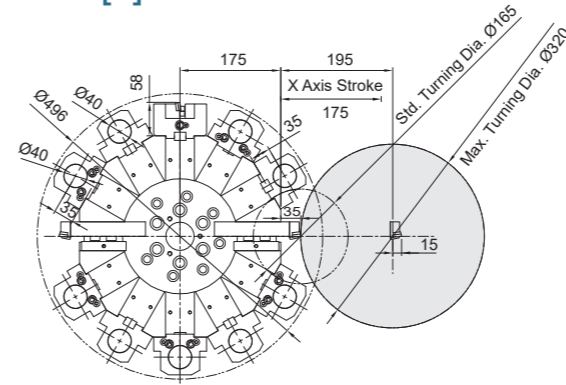

LA-200[L] T8

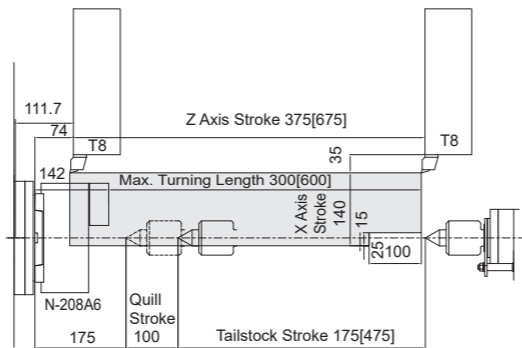
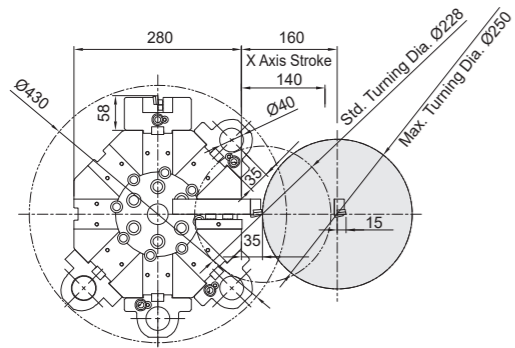

LA-200[L] T12

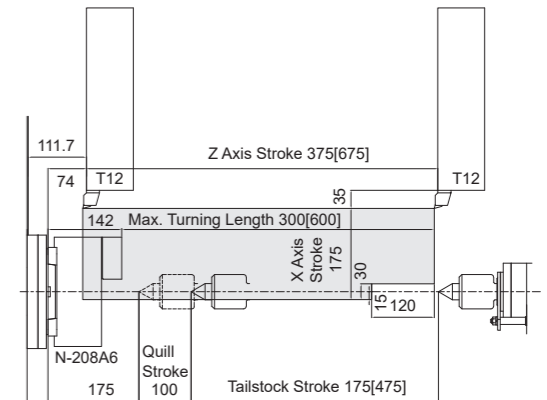
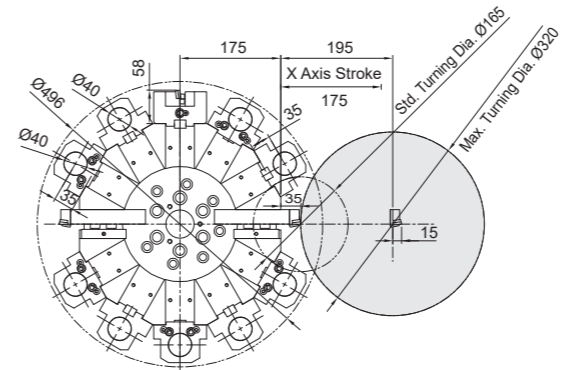

LA-150[L] T10

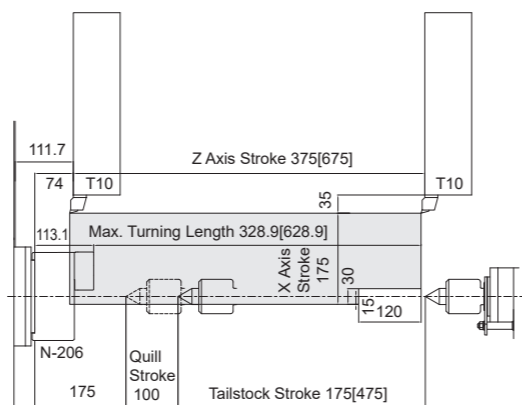
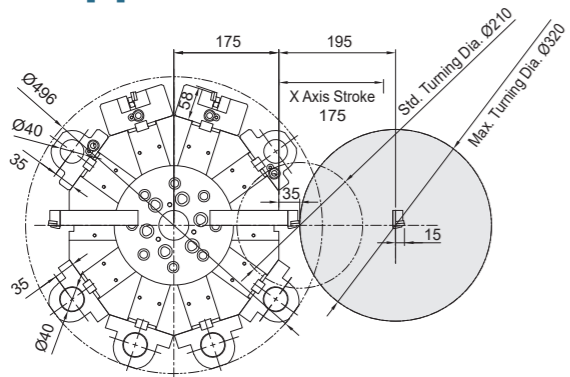

LA-150M[L] T12

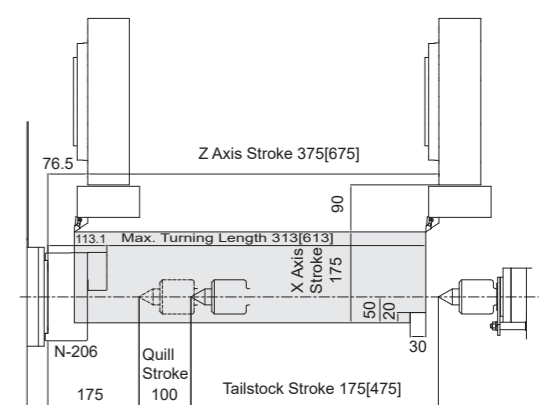
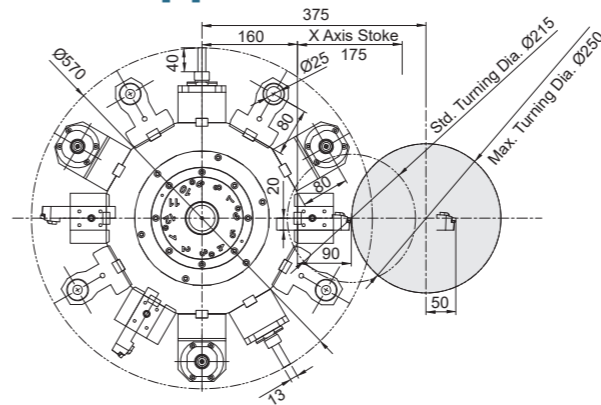

LA-200[L] T10

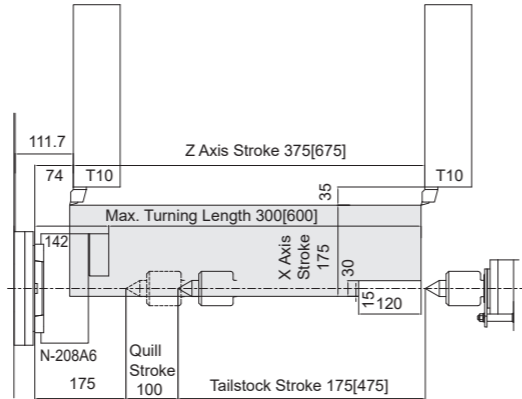
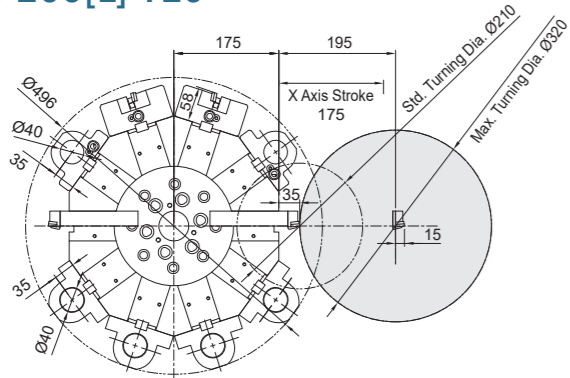

LA-200M[L] T12

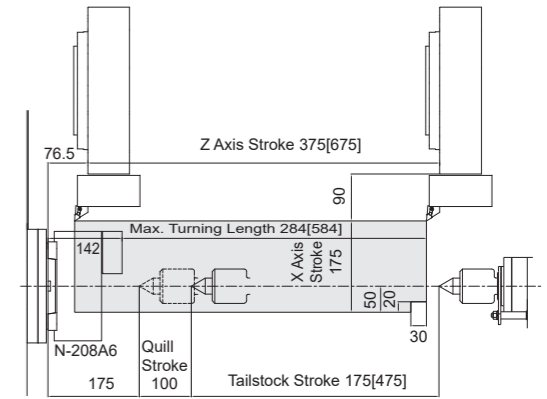
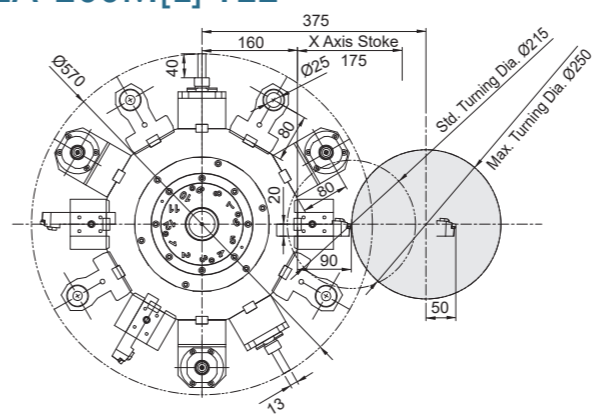

Machine Dimensions

LA-150 / LA-200

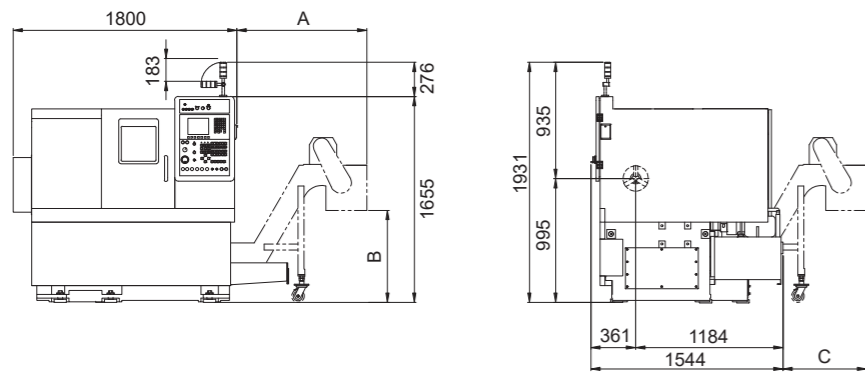

Chip Conveyor Dimension

	A	B	C
Standard	1044	900	673
CE	1044	740	673
Italy	1169	806	798
Switzerland	1269	1129	898

LA-150L / LA-200L

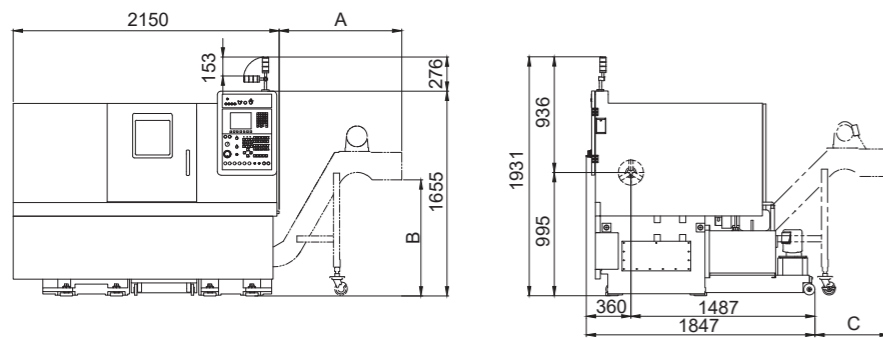

Chip Conveyor Dimension

	A	B	C
Standard	990	938	603
CE	990	938	603
Italy	1141	973	754
Switzerland	1141	1123	754

LA-150M / LA-200M

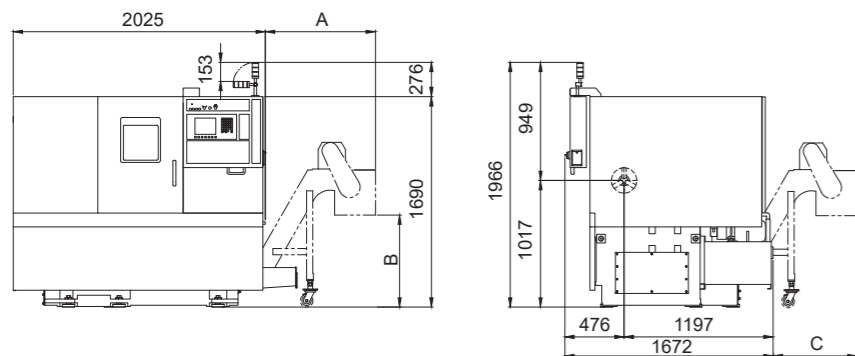

Chip Conveyor Dimension

	A	B	C
Standard	884	900	673
CE	884	740	673
Italy	1009	806	798
Switzerland	1109	1129	898

LA-150ML / LA-200ML

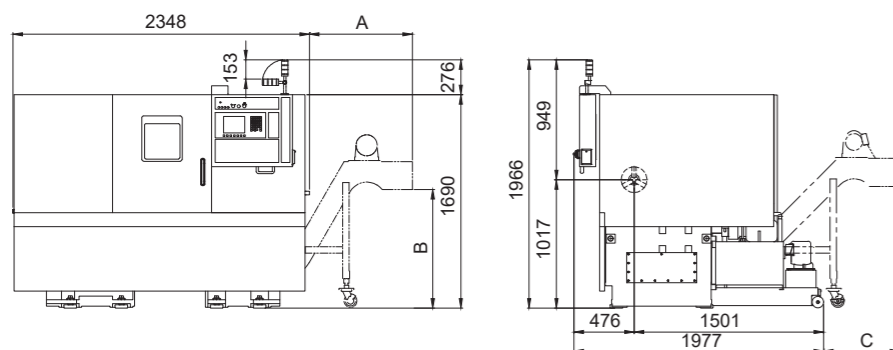

Chip Conveyor Dimension

	A	B	C
Standard	816	938	603
CE	816	938	603
Italy	967	973	754
Switzerland	967	1123	754

Tooling System

LA-150[L] / LA-200[L]

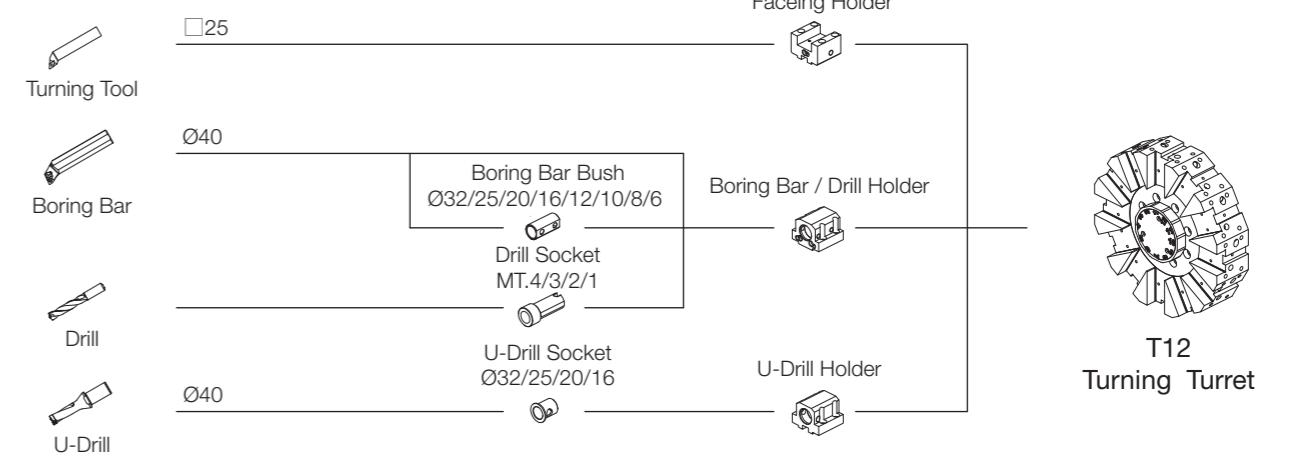

LA-150[L] / LA-200[L]

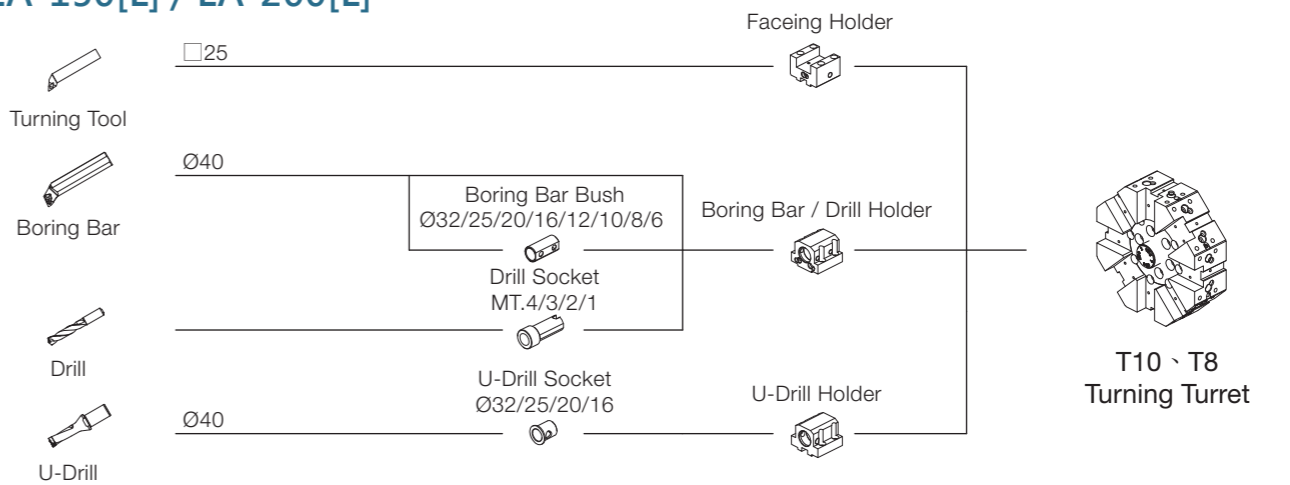

LA-150M[L] / LA-200M[L]

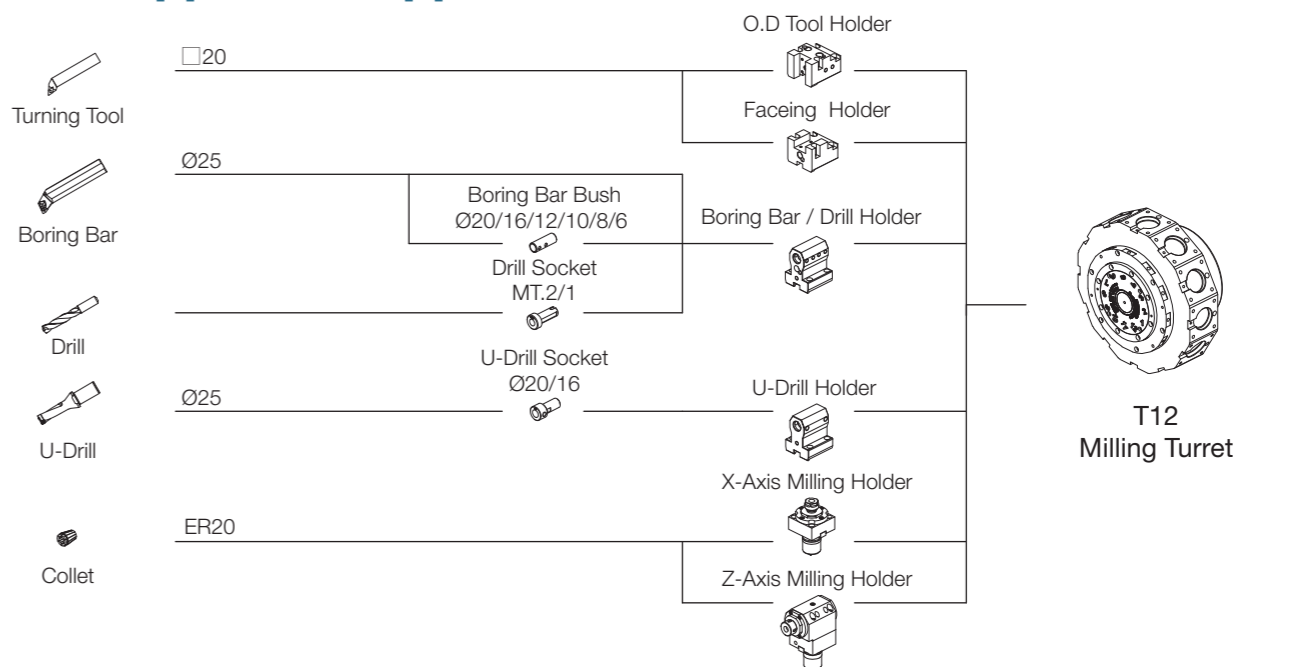

Machine Specification

Model		LA-150[L]	LA-150M[L]	LA-200[L]	LA-200M[L]
Item	Unit				
Capacity					
Max. Swing	mm	470	470	470	470
Standard Turning Diameter	mm	165 T12 Turret	215	165 T12 Turret	215
		210 T10 Turret		210 T10 Turret	
		228 T8 Turret		228 T8 Turret	
Max. Turning Diameter	mm	320 T12 Turret	250	320 T12 Turret	250
		320 T10 Turret		320 T10 Turret	
		250 T8 Turret		250 T8 Turret	
Max. Turning Length	mm	328 [628]	313 [613]	300 [600]	284 [584]
Max. Bar Work Capacity	mm	42	42	52	52
				66	66
Travel					
X-Axis Travel	mm	175 T12 Turret	175	175 T12 Turret	175
		175 T10 Turret		175 T10 Turret	
		140 T8 Turret		140 T8 Turret	
Z-Axis Travel	mm	375 [675]	375 [675]	375 [675]	375 [675]
Spindle					
Spindle Speed	rpm	5000	5000	3200	3200
				4000	4000
Spindle Nose		FLAT140	FLAT140	A2-6	A2-6
Through Hole Diameter	mm	53	53	63	63
				76	76
Bearing Inside Diameter	mm	80	80	100	100
				110	110
Turret					
Number of Tools		T12	T12	T12	T12
		T10		T10	
		T8		T8	
OD Tool Shank Dimension	mm	25	20	25	20
ID Tool Shank Diameter	mm	40	25	40	25
Milling Shank Diameter	mm	-	13 (ER20)	-	13 (ER20)
Milling Spindle Speed	rpm	-	4000	-	4000
Tailstock					
Tailstock Travel	mm	175 [475]	175 [475]	175 [475]	175 [475]
Tailstock Spindle Travel	mm	100	100	100	100
Tapered Bore Type		MT.4	MT.4	MT.4	MT.4
Tailstock Spindle Diameter	mm	75	75	75	75
Feedrate					
X-Axis Rapid Traverse	m/min	24	24	24	24
Z-Axis Rapid Traverse	m/min	24	24	24	24
Motor					
Spindle Motor	kW	11/7.5	11/7.5	11/7.5	11/7.5
Milling Spindle Motor	kW	-	2.2	-	2.2
Index Motor	kW	1.2	1.2	1.2	1.2
X-Axis Servo Motor	kW	1.2	1.2	1.2	1.2
Z-Axis Servo Motor	kW	2.5	2.5	2.5	2.5
Machine Size					
Height	mm	1655	1690	1655	1690
Width	mm	1800 [2150]	2025 [2348]	1800 [2150]	2025 [2348]
Depth	mm	1544 [1847]	1672 [1977]	1544 [1847]	1672 [1977]
Weight	Kg	3150 [3750]	3250 [3900]	3200 [3800]	3300 [3950]

※ Specifications are subject to change without notice.

Standard and Optional Accessories

● : Standard ○ : Optional --- : N/A

Item	LA-150[L] LA-200[L]	LA-150M[L] LA-200M[L]
Variable Speed Spindle	●	●
Pin Carry Tailstock with Live Center	○	○
Manual Tailstock with Live Center	○	○
T8 Turning Turret	●	---
T10 Turning Turret	○	---
T12 Turning Turret	○	---
T12 Milling Turret	---	●
O.D Tool Holder	---	●
Face Tool Holder	●	●
U-Drill Tool Holder	●	●
Boring Bar Tool Holder	●	●
Boring Bar Bush (Ø6、Ø8、Ø10、Ø12、Ø16、Ø20)	●	●
Boring Bar Bush (Ø25、Ø32)	●	---
U-Drill Bush (Ø16、Ø20)	●	●
U-Drill Bush (Ø25、Ø32)	●	---
Drill Bush (MT.1、MT.2)	○	○
Drill Bush (MT.3)	○	---
X-Axis Milling Holder	---	●
Z-Axis Milling Holder	---	●
Automatic Tool Setter	○	○
Manual Tool Setter	○	○
Linear Scales	○	○
Coolant Pump(450W)	●	●
Coolant Pump(715W、750W、900W)	○	○
Cutting Fluid Cooling	○	○
Hydraulic System	●	●
Nut Cooling Ball Screw	○	○
High Pressure Coolant	○	○
Hydraulic Oil Cooling	○	○
Hydraulic Pressure Sensor	●	●
Lubrication System	●	●
Lubricating Oil Recycling Box	●	●
Hydraulic Chuck	●	●
Collet Chuck	○	○
Foot Switch	●	●
LED Interior Light	●	●
LED Signal Tower	●	●
Hydraulic Steady Rest	○	○
Manual Steady Rest	○	○
Right Side Chip Conveyor	○	○
Rear Side Chip Conveyor	○	○
Chip Cart	●	●
Parts Catcher	○	○
Parts Conveyor	○	○
Automatic Bar Feeder and Interface	○	○
Electrical Auto Door	○	○
Pneumatic Auto Door	○	○
Safety Door Switch	○	○
Safety Light Curtain	○	○
Air Blow	○	○
Oil Skimmer	○	○
Oil Mist Collector	○	○
Parts Counter	○	○
Automatic Power-Off	○	○

※ Specifications are subject to change without notice.

High Speed Gantry Loder System

Layout Variations

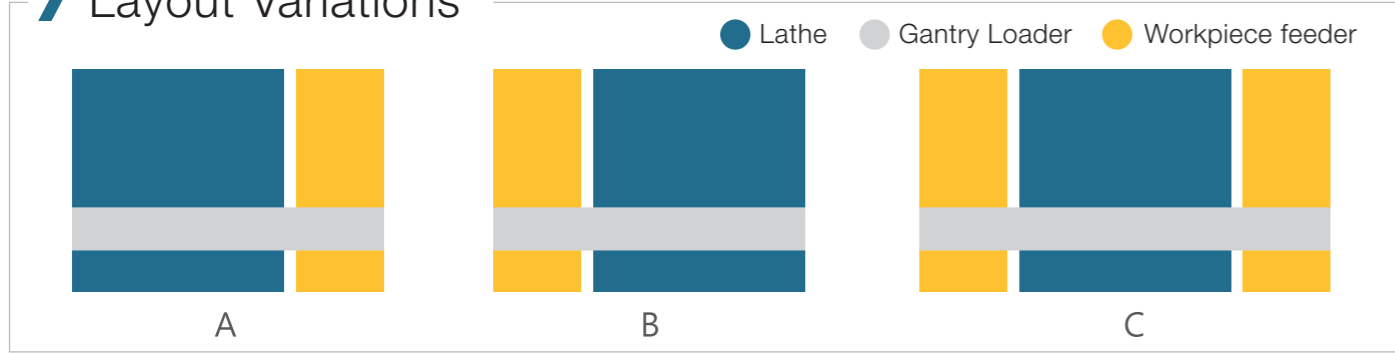

Peripheral Equipment

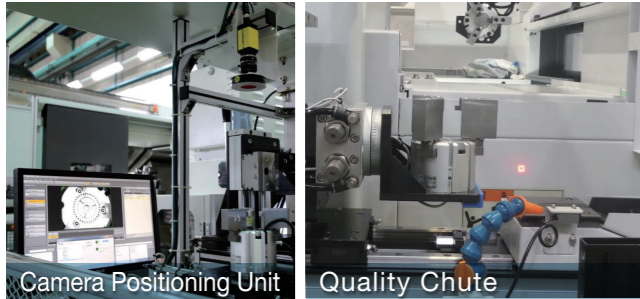
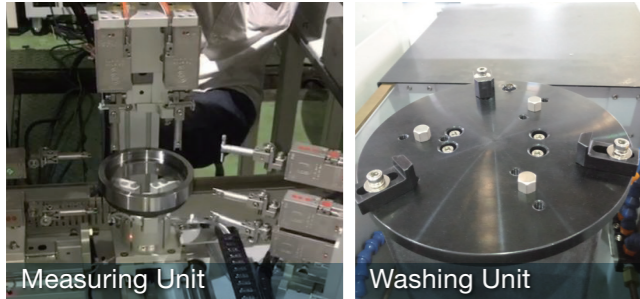

Gantry Loader Specifications

X axis	180	m/min
Z axis	150	m/min

Working Size

OD	160	mm
Length	100	mm
Weight	3(x2)	kg

Work Feeder Specifications

Pallet	16	pcs
Loading weight	40	kg
Max. Height	450	mm
Work feeder width	610	mm

Turn-Key Solution

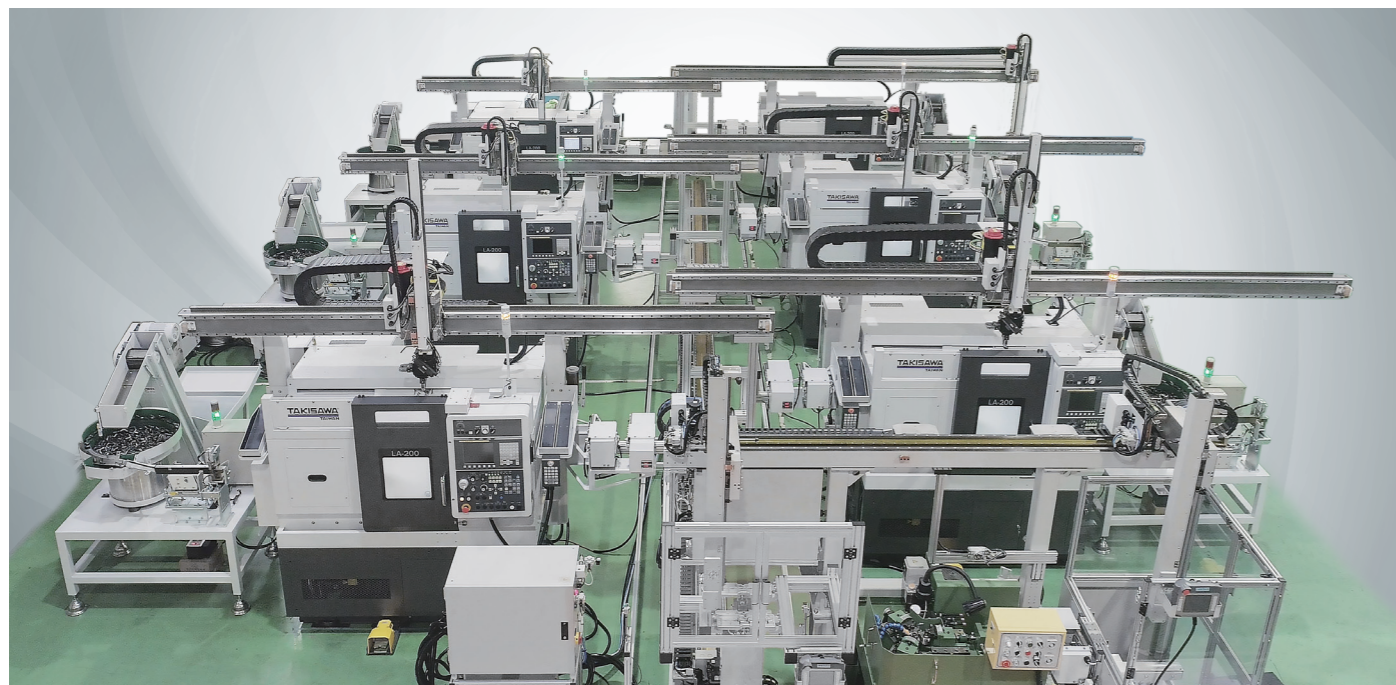

Customization

Side-in Gantry Loader



Parts Catcher

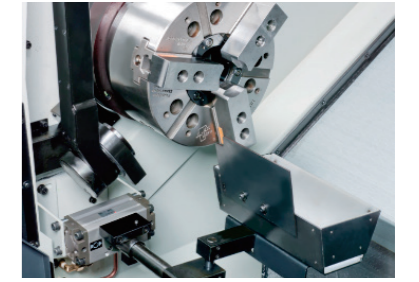

Customized Chuck

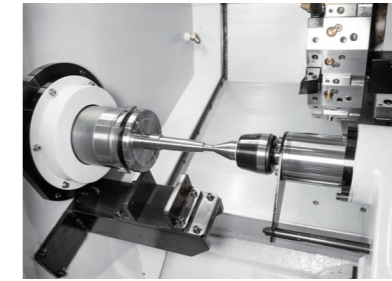
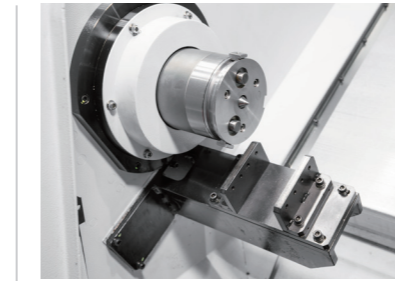

Parts Catcher & Conveyor

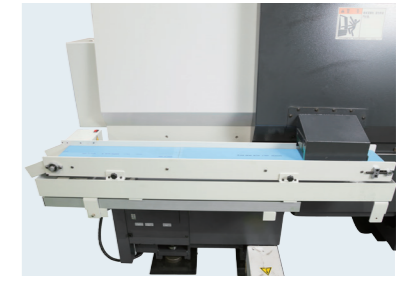

Twin Pneumatic Chuck



Automatic Tool Setter



Manual Tool Setter

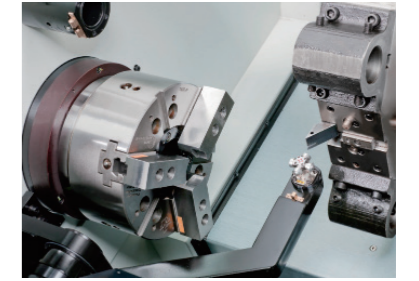

Highly Accurate Optional Equipment

There are special requirements for precise machining accuracy and it is necessary to use approved high-precision optional equipment.

Please contact us for advice on these options.

- 01 Linear Scales
- 02 Automatic & Manual Tool Setter
- 03 Nut Cooling Ball Screw
- 04 Cutting Fluid Cooling
- 05 High Pressure Coolant
- 06 Hydraulic Oil Cooling



NC Unit Specification

Controller	LA-150[L] LA-200[L]	LA-150M[L] LA-200M[L]
0I-TF	●	●
NC Unit	LA-150[L] LA-200[L]	LA-150M[L] LA-200M[L]
8.4" Color LCD	●	●
10.4" Color LCD	○	○
Safety Device	LA-150[L] LA-200[L]	LA-150M[L] LA-200M[L]
Front Door Interlock	○	○
Front Door Locking Mechanism	○	○
Safety Relay	○	○
Control Panel Breaker with Tripper	○	○
Controlled Axes	LA-150[L] LA-200[L]	LA-150M[L] LA-200M[L]
Least Input Increment	●	●
Maximum programmable Dimension(±999999.999)	●	●
Least Input Increment C	▲	▲
Inch/Metric Selection	●	●
Interlock	●	●
Machine Lock	○	○
Emergency Stop	●	●
Stored Stroke Check 1	●	●
Stored Stroke Check 2,3	●	●
Stroke Limit Check Before Movement	▲	▲
Chuck Tailstock Barrie	▲	▲
Mirror Image (Each Axis)	▲	▲
Chamfering ON/OFF	●	●
Overload Detection	▲	▲
Position Switch	●	●
Operation	LA-150[L] LA-200[L]	LA-150M[L] LA-200M[L]
Auto Run (Memory)	●	●
MDI Run	●	●
DNC Run	●	●
DNC Run with Memory Card	●	●
Program Number Search	●	●
Sequence Number Search	●	●
Sequence Number Collation and Stop	●	●
Wrong Operation Preventive	▲	▲
Buffer Register	●	●
Dry Run	●	●
Single Block	●	●
Jog Feed	●	●
Manual Reference Point Return	●	●
Dogless Reference Point Setting	●	●
Manual Handle Feed, 1 Unit	●	●
Interpolating Functions	LA-150[L] LA-200[L]	LA-150M[L] LA-200M[L]
Poitioning (G00)	●	●
Exact Stop Mode (G61)	●	●
Tapping Mode (G63)	●	●
Cutting Mode (G64)	●	●
Exact Stop (G09)	●	●
Linear Interpolation (G01)	●	●
Circular Interpolation (G02/G03)	●	●
Dwell (G04)	●	●
Polar Coordinate Interpolation	---	●
Cylindrical Interpolation	---	●
Thread Cutting	●	●
Multiple Thread Cutting	●	●
Thread Cutting Cycle and Retraction	●	●
Continuous Thread Cutting	●	●
Variable Lead Thread Cutting	●	●
Reference Point Return (G28)	●	●

Interpolating Functions	LA-150[L] LA-200[L]	LA-150M[L] LA-200M[L]
Reference Point Return Check (G27)	●	●
2nd Reference Point Return (G30)	●	●
3rd, 4th Reference Point Return	●	●
Feed Function	LA-150[L] LA-200[L]	LA-150M[L] LA-200M[L]
Rapid Traverse Override (F0,25%,50%,100%)	●	●
Feed Per Minute	●	●
Feed Per Revolution	●	●
Constant Tangential Speed Control	●	●
Cutting Feedrate Clamp	●	●
Automatic Acceleration/Deceleration	●	●
Rapid Traverse Bell-Shaped Accel/Decel	●	●
"Linear Accel/ Decel	●	●
After Feedrate Interpolation"	●	●
Feedrate Override (15 Steps)	●	●
Jog Override (15 Steps)	●	●
Override Cancel	●	●
Manual Feed Per Revolution	▲	▲
Program Input	LA-150[L] LA-200[L]	LA-150M[L] LA-200M[L]
Tape Code (EIA/ISO Auto Recognition)	●	●
Label Skip	●	●
Parity Check	●	●
Control In/Out	●	●
Optional Block Skip, 1 Piece	●	●
Optional Block Skip (2 to 9 Pieces)	⊕	⊕
Program Number O4 Digits	●	●
Program File Name 32 Characters	●	●
Sequence Number N8 Digits	●	●
Absolute/Incremental Command	●	●
Decimal Point Input/Pocket Calculator Type Decimal Point Input	●	●
Diameter / Radius Programming (X-Axis)	●	●
Coordinate System Setting (G50)	●	●
Auto coordinate System Setting	●	●
Drawing Dimension Direct Input	●	●
G-Code System A	●	●
G-Code System B/C	▲	▲
Chamfering/Corner R Programming	●	●
Programmable Data Input	●	●
Sub Program Call (10 Levels)	●	●
Custom Macro	●	●
Additional Custom Macro	●	●
Common Variables	●	●
Single Canned Cycle	●	●
Combined Canned Cycle	●	●
Combined Canned Cycle II	●	●
Drilling Canned Cycle	●	●
Arc Radius Programming	●	●
Macro Executor	○	○
Coordinate System Shift	●	●
Coordinate System Shift Direct Input	●	●
Miscellaneous Function/ Spindle Functions	LA-150[L] LA-200[L]	LA-150M[L] LA-200M[L]
M Function (M3 Digits)	●	●
Second Miscellaneous Function (B Function)	○	○
Spindle Functions (S4 Digits)	●	●
Constant Surface Speed Control	●	●
Spindle Orientation	●	●
Rigid Tap (Spindle Center)	●	●
Rigid Tap (Rotary Tool)	---	●

Data I/O	LA-150[L] LA-200[L]	LA-150M[L] LA-200M[L]
RS-232C Interface for 1 ch	●	●
Fast Data Server	⊕	⊕
External Message	●	●
External Workpiece Number Search	○	○
Memory Card I/O	●	●
Tool Functions/Tool Offset Functions	LA-150[L] LA-200[L]	LA-150M[L] LA-200M[L]
T Function (T2+2 Digits)	●	●
Tool Offsets, 99 Pieces	●	●
Tool Offsets, 200 Pieces	○	○
Tool Geometry Size Data, 100 Pieces	○	○
Tool Position Offset	●	●
Tool Diameter /Nose R Compensation	●	●
Tool Geometry /Wear Compensation	●	●
Tool Offset Counter Input	●	●
Tool Offset Measured Value Direct Input	●	●
Tool Offset Measured Value Direct Input B	○	○
Tool Life Management	▲	▲
Accuracy Offset Functions	LA-150[L] LA-200[L]	LA-150M[L] LA-200M[L]
Backlash Compensation	●	●
Backlash Compensation by Rapid Traverse / Feedrate	●	●
Editing	LA-150[L] LA-200[L]	LA-150M[L] LA-200M[L]
Part Program Memory Capacity 512Kbyte (1280m)	●	●
Part Program Memory Capacity 2Mbyte	○	○
Registrable Programs, 400 Programs	●	●
Registrable Programs, 1000 Programs	○	○
Program Editing	●	●
Program Protection	●	●
Extended Program Editing	●	●
Background Editing	●	●

Setting/Display	LA-150[L] LA-200[L]	LA-150M[L] LA-200M[L]
Status Display	●	●
Clock Function	●	●
Current Position Display	●	●
Program Comment Display (31 Characters)	●	●
Parameter Setting and Display	●	●
Alarm Display	●	●
Alarm Log Display	●	●
Operator Message Log Display	●	●
Operation Message Log Display	●	●
Run Hours and Parts Count Display	●	●
Actual Speed Display	●	●
Actual Spindle Speed and T Code Display	●	●
Floppy Cassette Directory Display	●	●
Grouped Directory Display and Punching	●	●
Servo Adjustment Screen	●	●
Maintenance Information Screen	●	●
Data Protection Key, 1 Kind	●	●
Help Function	●	●
Self Diagnostic Function	●	●
Scheduled Maintenance Screen	●	●
Hardware & Software System Configuration Display	●	●
Graphic Display	●	●
Dynamic Graphic Display	○	○
Display Languages	LA-150[L] LA-200[L]	LA-150M[L] LA-200M[L]
English	●	●
Japanese (Kanji)	▲	▲
Other Language	▲	▲
Display Language Dynamic Switching	●	●

●:Standard ○:Optional ⊕:Special ▲:Parameter setting is required ---:Nope

Smart Work Manager (option)

It provides simple operation and convenient function.

01

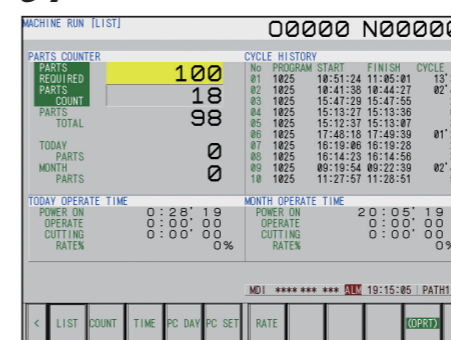

Tool Life Manager

This function can set tool life and wear limit to manage all tools.

02



Load Monitor

Detecting max load to check tool status.

03

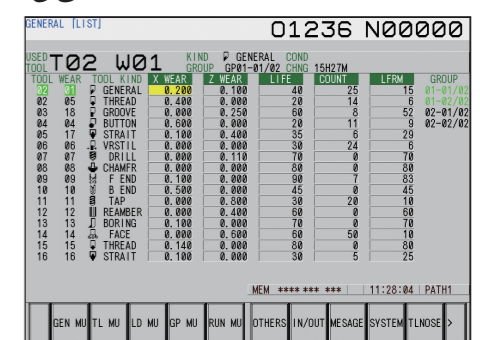

Parts and Machine Manager

It offer parts counter, program history, operate time for today or this month.